

e-Forms on State Portal and SSDG Project

Implementation Guidelines

Department of Information Technology
Government of India

Table of Contents

| | | |
|-------|-----------------------------------------------------|----|
| 1 | Background | 4 |
| 2 | Objective | 5 |
| 3 | Scope of the project | 6 |
| 3.1 | e-Form application and State Portal..... | 6 |
| 3.2 | State Service Delivery Gateway (SSDG)..... | 7 |
| 3.3 | Gap Infrastructure | 8 |
| 3.4 | Training & Manpower for SSDG and State Portal | 8 |
| 3.5 | Compliance/Certification by STQC..... | 8 |
| 3.6 | Operations & Maintenance..... | 9 |
| 4 | Timelines of the project | 9 |
| 5 | Governance Structure..... | 10 |
| 6 | Roles and Responsibilities | 13 |
| 6.1 | State Nodal Agency | 13 |
| 6.2 | State Departments..... | 14 |
| 6.3 | NIC..... | 14 |
| 6.4 | C-DAC | 15 |
| 6.5 | STQC | 15 |
| 6.6 | Common Service Centers (CSC)..... | 15 |
| 6.7 | Citizen as Service Seeker | 16 |
| 6.8 | Content Service Provider (CSP)..... | 16 |
| 6.9 | Consultant..... | 16 |
| 6.10 | Implementation Agency..... | 16 |
| 7 | Components of the system | 17 |
| 7.1 | State Portal | 17 |
| 7.1.1 | State Portal Framework | 18 |
| 7.2 | State Service Delivery Gateway (SSDG)..... | 19 |
| 7.2.1 | SSDG Manuals | 21 |
| 7.2.2 | Registration of Department and Services | 22 |
| 7.2.3 | Routing of e-Forms by SSDG..... | 23 |
| 7.3 | e-Forms application | 25 |
| 7.3.1 | e-Forms Standards (Meta data Standards)..... | 26 |
| 8 | Integration with other MMPs | 27 |

Implementation guidelines

| | | |
|---------|---------------------------------------------------------------------------------------|----|
| 8.1 | Scenario 1 – State Department with Non - Automated Backend IT System | 27 |
| 8.2 | Scenario 2 – State Department with Automated Backend IT System | 29 |
| 8.3 | Scenario 3 - State Department with Partially Automated Backend IT System..... | 30 |
| 9 | Acceptance Criteria..... | 31 |
| 10 | Checklist..... | 33 |
| 11 | Helpdesk..... | 34 |
| 11.1 | Contact Information | 34 |
| 11.1.1 | DIT, NIC and CDAC contacts..... | 34 |
| 12 | Terminology | 35 |
| 12.1 | Acronyms | 35 |
| 12.2 | CSC..... | 35 |
| 12.3 | SWAN..... | 36 |
| 12.4 | SDC..... | 36 |
| 12.5 | India Portal | 37 |
| 13 | Annexure | 38 |
| 13.1 | Annexure I -List of empanelled Implementing Agencies with their contact details | 38 |
| 13.2 | Annexure II --List of empanelled Consulting Agencies with their contact details | 38 |
| 13.3 | Annexure III – Chronological list of E-Form, State Portal SSDG Activities | 39 |
| 13.4 | Annexure IV --List of identified 40 e-Forms | 41 |
| 13.5 | Annexure V- Service Delivery Models..... | 44 |
| 13.6 | Annexure VI – e-Forms PoC by CDAC and Learnings | 46 |
| 13.6.1 | PoC overview..... | 46 |
| 13.6.2 | e-Form PoC architecture | 46 |
| 13.6.3 | E-Form design..... | 48 |
| 13.6.4 | Officer view of the application form..... | 51 |
| 13.6.5 | Fulcrum – e-Forms Designer Tool from C-DAC | 52 |
| 13.6.6 | Destination office processing and MIS reports | 53 |
| 13.6.7 | Destination Office Processing | 53 |
| 13.6.8 | Dashboard for Department | 54 |
| 13.6.9 | Flow Diagram - e-Forms PoC..... | 55 |
| 13.6.10 | Learnings from e-Forms PoC | 57 |
| 13.7 | Annexure VII - Guidelines for States and Implementation Agencies | 59 |
| 13.8 | Annexure VIII - Security Services by SSDG for SP/ Govt. Dept. | 62 |
| 13.9 | Annexure IX- Electronic Service Delivery (ESD) Rules..... | 64 |
| 13.10 | Annexure X - Status report template | 71 |

1 Background

The e-Forms (Electronic Forms) on state portal and SSDG project has been formulated under the National e- Governance Plan (NeGP). The NeGP plan of the Govt. of India aims to make all Government services accessible to the common man in his locality, through common service delivery outlets and ensure efficiency, transparency & reliability of such services at affordable costs to realize the basic needs of the common man.

e-Forms application will enable citizens to download forms and submit their applications electronically with help of **Electronic Forms** hosted on the **State Portal (SP)** and routed by a common **services gateway (SSDG)**. This important initiative facilitating Electronic Service Delivery will provide significant benefits to the citizens especially in the form of a single gateway to citizen for service delivery. The project will guarantee the following:-

- a. Assured electronic delivery of the request from the citizen to the specified field office of the government department
- b. The electronic acknowledgement of successful submission of application/request from department to the citizen.
- c. Citizen will be able to query the status of his/her application/request at any point in time.
- d. Request/ response will also be conveyed through the SSDG. (which may initially be limited to notification that the license, permit, etc. is ready to be picked up)

The objective of the State Portal & SSDG scheme is to ensure the following:

- i. Providing easy, anywhere and anytime access to Government Services (both Information & Transactional)
- ii. Reducing number of visits of citizens to a Government office / department for availing the services
- iii. Reducing administrative burden and service fulfillment time & costs for the Government, Citizens & Businesses
- iv. Reducing direct interaction of citizen with the Government and encourage 'e'-interaction and efficient communication through portal
- v. Enhancing perception & image of the Government and its constituent Departments
- vi. Promotion of uniform web interface across Government departments and to build in synergies with the National Portal of India (NPI) using the National Service Delivery Gateway (NSDG).

Implementation guidelines

- vii. Delivery of services through Common Service Centers (CSCs) by leveraging the common infrastructure (SWAN, SDC etc.) and development of the applications and infrastructure required for deployment of State Portal and State Service Delivery Gateway (SSDG) for the State.
- viii. Publishing the static data and all information of the State departments in line with guidelines for necessary integration with NPI

The processing at the backend of the department may initially continue to be in a manual mode. Gradually as the MMPs and other State applications get implemented and the backend gets computerized, the functionality of the services provided will get enhanced and eventually all services that can be provided online could be accessible via State Portal in integrated fashion.

2 Objective

The objective of this document is to provide all the information needed by the state and the implementing agencies for the e-Forms through State Portal and SSDG project and provide implementation guidelines for this project. State officials, implementing agencies, consultants could use this document as a ready reckoner for this project.

The document details the scope, timelines, governance structure, roles and responsibilities of the e-Forms project in section 3, 4, 5, and 6 respectively. Section 8 details the architecture, flow diagram and integration scenarios of the application. Acceptance Criteria, checklist, helpdesk and terminology are dealt with in sections 9, 10, 11 and 12 respectively.

The annexure section includes:-

- Annexure I - List of empanelled Implementing Agencies
- Annexure II -List of empanelled Consulting Agencies
- Annexure III – E-Form, State Portal SSDG steps
- Annexure IV - List of identified 40 e-Forms
- Annexure V – Service delivery models
- Annexure VI – e-Forms PoC and Learning
- Annexure VII – Guidelines for states and Implementation agencies
- Annexure VIII – Security Services by SSDG for SP/ Govt. Dept.

- Annexure IX – Electronic Service Delivery (ESD) Rules
- Annexure X- Status report template

3 Scope of the project

The broad details for all the components of the Project are given below: These shall be detailed out in the Functional Requirement Specification (FRS) prepared by the consultant.

3.1 e-Form application and State Portal

- a) Design and development of the State Portal according to the State Portal Framework (SPF) provided by NIC (www.spf.india.gov.in)
- b) At design stage the implementation agency shall develop appropriate screen layouts for the portal.
- c) Development of the following services is mandatory:-
 - Metadata Replication Service as per the SPF
 - Government Office Directory
 - Service Locator
- d) Integration of the State Portal with the NPI for exchange of content through metadata & seamless exchange of services (as specified in SPF)
- e) Design and development of the e-Form application in Secure & Usable format. All the hosted e-Forms shall have the option of online and offline submission. The departments, services, location of the services which are to be part of the e-Forms application would be detailed out in the Request for Proposal (RFP).
- f) e-Form Application would have the following components:-
 - Front End component of the application on the State Portal hosting the e-Forms.
 - Back end for storing the applications, printing, status update and MIS application.
 - Providing automatic acknowledgement with automated date and time stamping.

Implementation guidelines

- Enabling tracking of the status of the application from any authorized office through a unique application ID.
 - Routing based on the location parameters in the forms and the departmental service registration.
- g) Customization of the connectors provided by C-DAC for integration of the e-Form application with SSDG.
- h) Development of role based, workflow driven by web based Content Management System (CMS) for contribution of any type of content to the State Portal including the metadata as specified in SPF.
- i) Operation and Maintenance of the Portal and e-Form Application including bug-fixes and problems as indicated by the states for 3 years from the date of **release after successful UAT by STQC** of << n >> services of << d >> departments..
- j) Detailed user and operational manuals to be provided to each department, whose services will be hosted on the portal.
- k) Implement/add any additional forms of state departments as and when the departments are ready for delivering.
- l) The implementation agency shall indicate the type of services to be made available using helpdesk support.
- m) Leverage and integrate the existing e-Services applications (developed either through e-District or through state government initiatives) with e-Forms on State Portal and SSDG application.

3.2 State Service Delivery Gateway (SSDG)

- a) Installation & commissioning of SSDG which will act as a hub for all the interactions among service seeker & providers. The original SSDG product for the above will be provided by C-DAC.
- b) Integration of SSDG with N S D G, National Services Directory (NSD) and State Portal.
- c) Operation and maintenance of the SSDG software product and the SSDG stack for 3 years from the date of go-live.

3.3 Gap Infrastructure

Supply and installation of gap infrastructure at various department offices and different locations within the State. Gap infrastructure includes-

- a) Computing infrastructure - computer, printer, scanner and UPS.
- b) Connectivity infrastructure which will connect the horizontal field offices where applications are processed. Note - The bandwidth from the telecom service provider would be made available by State.
- c) The details of number of offices and the units of gap infrastructure per office will be provided by the State IT department.
- d) Maintenance of the computing and connectivity infrastructure for 3 years and training support to be imparted to the end user.

3.4 Training & Manpower for SSDG and State Portal

The objective is to build internal capacities to support the line departments of the State on an on-going basis for e-Forms, new application integration, service registration etc. on SSDG /Portal and continuity when the implementing agency (IA) exits.

It is proposed to train a minimum of 2 employees per respective department per year for processing of e-Forms, SSDG & State Portal Maintenance & Management. Employees from each department whose content & service will be published or exchanged on the portal, SSDG and e-Form processing will be selected. The composite team would also be trained on all these components to take care of O&M operations of the application once the IA exits. Training shall encompass SPF & website guidelines, SSDG understanding and e-Form processing.

3.5 Compliance/Certification by STQC

Quality certification of these components of the project i.e. Portal including SPF, e-Forms application and SSDG is mandatory. The STQC will be the designated agency to perform this task.

3.6 Operations & Maintenance

Operation and Maintenance of the Portal and e-Forms Application for 3 years from the date of release after successful UAT by STQC of selected services of selected departments as detailed in RFP.

During design, development, implementation, testing and O&M, the implementation agency needs to

- a. Follow configuration management rules and industry standard guidelines for all documents as well as code. Only those documents and code which are approved in reviews should be used.
- b. Provide status reports and participate in status reviews.
- c. Provide all necessary documentation.
- d. Submit internal review, testing results and necessary documents (e.g. – If the Implementation Agency performs internal code review, then corresponding results and document should be submitted to the department. All the internal review and test plans should be mentioned by the Implementation Agency in the detailed project plan to be submitted at the stage of project initiation.)
- e. Help desk support as agreed upon by the State and IA.
- f. Implementation of the incremental additional services identified by the State.

4 Timelines of the project

To kick-start the State portal initiative, DIT has requested all States/UTs to select a consultant from the empanelled five consultants. The States/UTs are requested to prepare project proposals for the implementation of e-Forms on State Portal and SSDG in the respective State/UT. These state proposals, once approved by DIT, will be used as one of the inputs to the Functional Requirement Specification (FRS) and Request for Proposal (RFP) to be prepared by the consultant.

Implementation guidelines

DIT has empanelled five implementing agencies through a central empanelment process. These implementing agencies will be responsible for implementing the State Portal and e-Forms in the States/UTs. The consultant will be required to assist the state in selecting one of these implementing agencies through a RFP tendering process. The creation of the RFP will be preceded by an extensive requirements gathering exercise aimed at defining the scope of work of the implementing agency resulting in the creation of the FRS. After an implementing agency is selected, the consultant will be required to support the State/UT in monitoring the implementation of the project.

The project shall be implemented by the Implementation Agency within a period of 6 months or earlier and it shall be followed by an Operations and Maintenance phase of 3 years. The target is to have at least 10 states go live with the implementation of this project by October 2010. The different activities of the project in chronological order are available in Annexure III.

5 Governance Structure

The Governance Framework has Central and State components.

Following figure gives the overall Governance Structure:

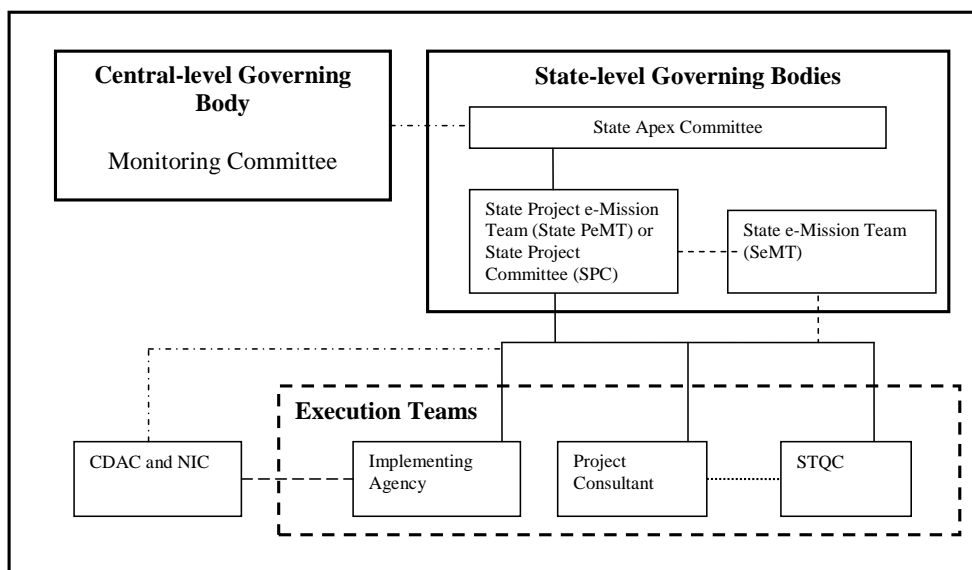

Exhibit 1 – Governance Structure

A. Central Level Governance

1. Monitoring Committee composition

- Additional Secretary (e-Governance), GoI
- Joint Secretary (e-Governance), GoI
- Secretary IT (Respective State / UT)
- Director (CSC), GoI
- Representative from NIC,
- Representative from C-DAC
- DFA, DIT
- Director (e-Gov) / Joint Director (e-Gov), GoI

Role and Responsibilities

- To review the financial and technical progress of the project
- To assess the progress of work on the project and to advise the project execution team on new directions / approach and ensure its smoother progress and link-up with the work going on elsewhere in the country for full utilization of the capabilities available in the country.
- To examine specific request from State / State Nodal Agency regarding changes in sanctions and to make recommendations thereon for consideration by the Empowered Committee.

Implementation guidelines

- d) To ensure advance action regarding completion of the project, establishment of facilities. Its utilization and transfer of know how etc. for successful replication.
- e) Review the deliverables of the agencies involved and amends the deliverables of required keeping in view the project objective.

B. State Level Governance

The suggested composition of each of the governing bodies described in the earlier figure is as follows:

1. State Apex Committee

The State Apex Committees, under the chairmanship of Chief Secretary, are already formed as per the Operational Guidelines issued by the DIT.

Role and Responsibilities

- a) Approval of departments and services for which e-Forms need to be implemented and associated processes for service delivery through the CSCs.
- b) Approval of the formalization of changes required in the departmental processes, BPR and Change management
- c) Laying down the respective duties and obligations of each entity including that of CSC/SCA in respect of each service to be made available electronically.
- d) Decisions on Policy matters.
- e) Issue of necessary government orders and notifications for enablement of e-Form services through CSCs
- f) Ensure integration with other MMPs like e-District etc
- g) Financial authority for all approvals
- h) Periodic review of project progress
- i) Address any interdepartmental issues if required.
- j) Overall guidance and directions for speedy implementation of the project.

2. State Project e-Mission Team (State PeMT)

At the State level, the State Project e-Mission Team (State PeMT), also known as State Project Committee (SPC), supported by the State e-Mission Team (SeMT), will oversee the implementation of the project.

Indicative composition:

- IT Secretary (Mission Leader)
- Representative from State Nodal Agency

Implementation guidelines

- HODs/Representatives from concerned departments
- Representative from C-DAC
- SIO, Representative from NIC
- Any other person deemed fit by Mission Leader

Role and Responsibilities

- a) Overall project leadership and responsibility to oversee Project implementation and monitoring including coordination with NIC and C-DAC for technical support on the project.
- b) Prioritization of departments and services for which e-Forms need to be implemented.
- c) Examine, review and approve the deliverables of Consultants/ Implementing agencies and recommend for approval to Apex committee
- d) Examine and enable formalization of changes required in the departmental processes and Review the progress of implementation of BPR and Change management
- e) Review and approval of the RFP.
- f) Manage tendering process for selection of Consultant/Implementation Agency(ies)/Content Service Provider/Data entry agency/ies and recommend for approval to apex committee
- g) Manage Communications and Training plan.
- h) Assess the progress of work on the project and advice the project execution team on new directions/approach and ensure its linkage with related work in the concerned departments
- i) Exercise strategic control including budget controls
- j) Ensure Certification from STQC before full State level roll-out
- k) Serve as secretariat for State Apex Committee for the Project
- l) Ensure ongoing support during Operation and Maintenance period and smooth handover after 1+ 3 years of operation.

3. State e-Mission Team (SeMT)

The SeMT shall support the State PeMT (SPC) in project implementation and shall build up necessary capacities to manage the project on an ongoing basis.

6 Roles and Responsibilities

6.1 State Nodal Agency

State Nodal Agency will have the overall responsibility for the smooth implementation of the whole project. PeMT (SPC) setup under the nodal agency in the State would oversee the implementation of the project. State Nodal Agency shall formalize arrangement with the

Implementation guidelines

concerned departments, regarding processing of electronic requests received. State would also arrange a meeting with IA, STQC and NIC, once the IA is selected through the bid process, to bring all the stakeholders on a common understanding regarding their scope of work and their roles and responsibilities.

6.2 State Departments

- a) State shall provide the content, forms and other details to be published on State Portal.
- b) State shall provide services to be offered on the portal for e-filing of the applications.
- c) State shall issue necessary guidelines for processing of e-Forms to all the locations/offices.
- d) During the Operations and Maintenance phase of the project the State shall indicate the incremental additional services to be provisioned based on the requirements. This shall be subsequently highlighted in the RFP to be released by the state for selection of the empanelled Implementation Agency.
- e) State shall monitor the processing of the applications / service requests raised by the citizens against the set service levels which shall involve the following steps:
 - Taking the printout of the e-Form
 - Processing it like any other paper based application
 - Updating the status of application on the State Portal from time to time
 - Informing the applicant to come to office with the relevant documents and fees, if applicable, to receive the certificate/license/permit etc.
 - Providing service on production of supporting documents / physical presence of the applicant

6.3 NIC

- a) NIC shall provide the SPF, Website Guidelines and the necessary standards.
- b) NIC shall provide the technical advice/consultation to the Implementation Agency for the development of State Portal in accordance with SPF, integration of Content & exchange of Services between State Portal and National Portal.

6.4 C-DAC

- a) C-DAC shall provide the SSDG software product along with the SSDG complete stack (BOSS+JBOSS+PostgreSQL) and shall do the centralized maintenance and version control of the executables/ product.
- b) C-DAC shall provide the technical assistance to the Implementation Agency for implementation of the connectors to integrate the e-Form application on State Portal & backend of e-Form Application with SSDG. Each of the SSDG communicates with NSDG and NSD. NSDG is the middleware at the centre integrating and connecting applications of central line ministries. NSD is the central directory holding information regarding all the services registered with NSDG and all SSDG's. Please note that NSD and NSDG integration is inbuilt in SSDG.
- c) C-DAC shall provide the training to Implementation Agencies at various levels such as overview, administration and trouble shooting of SSDG. Implementation Agency should get their staff certified from C-DAC for the same.
- d) C-DAC shall provide the necessary user manuals and guidelines for the SSDG implementation.
- e) C-DAC shall provide generic connectors in Java and .Net for State Portal and e-Form Application of the department.

6.5 STQC

The STQC is the agency designated for carrying out the conformity assessment of various components of the project i.e. Portal, Application and e-Forms and SSDG. STQC will be paid by the State directly at the end of the testing by STQC. During design and development phase STQC would be involved as agreed amongst STQC, IA and state.

6.6 Common Service Centers (CSC)

- a) CSCs shall provide facility to the citizens for e-filing the forms for the hosted services.
- b) CSCs shall provide status update, acknowledgement of the applications to the citizens and any other associated activity agreed at the State level.

6.7 Citizen as Service Seeker

- a) Service seeker selects and fills the e-Form
- b) S/he submits the form electronically
- c) S/he gets unique ID generated by the system, to follow up the case and to know the status

6.8 Content Service Provider (CSP)

CSP identified by the State for the National Portal project may be used and CSP shall be responsible for creation, compilation, packaging & contribution as well as maintenance of the content on the State portal through the CMS developed by IA. In case CSP is not in place then State Government may select a CSP.

6.9 Consultant

The selected consultant would be responsible for

- a) Finalization of the process flow for the list of services to be e-Form-enabled with the help of the State.
- b) Assisting State / UT's in finalizing the content to be published.
- c) Recommendation of the appropriate change management strategy and communication plan, including training needs of the departmental functionaries after due assessment.
- d) Assisting the state government in finalizing the processes and approval/amendment of the Government orders.
- e) Preparation of the FRS for the e-Forms application.
- f) RFP Creation
- g) Bid Process Management
- h) Implementation Support
- i) UAT certification

6.10 Implementation Agency

The implementing agency for each State / UT is to be selected from among the 5 empanelled agencies through the limited RFP process. Once selected and contracted, the Agency will undertake the implementation work of the Project. Two implementation options were listed in the Request for Qualification for empanelment Agencies

Implementation guidelines

Option 1: The State could choose one of the empanelled agencies as the Implementation Agency (IA) for the entire scope of work of this project. In this case, NIC would be given (directly by the state) professional charges for their guidance on SPF.

Option 2: In a few states where Portal development is already at an advanced stage and where NIC is actively involved in the same, State could assign NIC as the IA for the implementation of the Project. However, the NIC (or State) could engage one of the empanelled agencies for other activities such as SSDG, e-Forms application development, Computing Infrastructure and Connectivity and any support required in O&M activities based on RFP issued as per the approved DPR. The state would decide on the funds to be given to NIC based on the scope of work of NIC.

7 Components of the system

7.1 State Portal

With the CSCs at the forefront for the end user, the State Portal will act as front end interface to State level e-Governance initiatives and services. The Portal and SSDG project infrastructure is expected to be hosted in the State Data Center (SDC). However, if there is no SDC at the time of implementation, then the State would implement it in SWAN PoC or any other Data Centre like NIC or SWAN PoC and state would mandate the IA to migrate the infrastructure in the SDC whenever it comes up during the operations period

Comment [k1]: Repeting SWAN PoC

The basic functionalities required through the State Portal are:

- i. **Information Dissemination:** The portal will provide information about Government departments, line ministries, and web links to these departments. It will provide information about Government structure in the state, service offerings, key notifications etc to the business and citizen community. Content Architecture of the Portal shall be in accordance with SPF.
- ii. **Multilingual:** The portal would primarily be available in local language & English.
- iii. **Shall be available anytime, anywhere:** The portal will be available 24 hours a day, 7 days a week, and accessible from anywhere in the world via the internet. While the

Implementation guidelines

technology shall be available round the clock, functional support might be available only during the normal working day.

- iv. Shall be accessible from a variety of channels: The portal can be accessed via a variety of established channels, including Individual users (through PCs), CSCs, Government Service delivery counters, mobile phones etc.
- v. Shall exchange information & services seamlessly across State Government departments. This exchange should be in accordance with SPF.
- vi. The State Portal shall also host all the e-Forms for various Government Services accessible to citizens in the State. A citizen will be able to fill the form electronically (both online and offline) through internet services including CSCs outlets and submit his/her application. A citizen will be able to track the status of his/her application / request at any point in time. Portal development shall include development of a complete application for electronic receipt of forms by the destination office, MIS, printing, accounting, status reporting, query service and payment handling. (This scope of work can be split between NIC and IA as discussed in implementation option 2 in the roles and responsibilities of IA section 6.10)

7.1.1 State Portal Framework

Present State Portal implementation varies significantly from state to state in terms of information provided, user interface, technologies used etc. Absence of common standards makes it impossible to exchange any information among State Portals as well as between State Portal & other state government websites.

The primary objective of SPF is to enable development and maintenance of State Portals, which complies with prescribed guidelines & standards to facilitate:

1. Standardization of state government portals in terms of user experience
2. Exchange of content between state government portal, and other websites, web portals & e-governance applications of State government departments & organizations.
3. Guidance towards development of sharable, accessible and interoperable departmental services to state government portal & National portal.

Implementation guidelines

4. Consolidation of all the information presently available at existing state department websites and portals.
5. Digitization of forms related to various government services
6. Integration of the State Portal with the National Portal.

For portal framework document and further details please visit the website <http://spf.india.gov.in/>

7.2 State Service Delivery Gateway (SSDG)

One of the goals of the State Government is to cooperate, collaborate and integrate information across different departments in the State. To simplify the above task, the concept of e-Governance Service Delivery Gateways has been conceptualized that will act as standards-based messaging switch and provide seamless interoperability and exchange of data across the departments.

The functionality of the State Level gateway is similar to the NSDG at the Centre and shall work peer to peer with the Central NSDG and other Gateways. It shall use the National Level NSD to carry out address resolution of the services listed on other gateways across the country. All the State services shall be listed in this directory.

The figure below depicts the positioning of the gateway in the SDC and the external entities interacting with the gateway for exchange of data using IIS/IIP message formats and protocols. The gateway thus enables interaction between various departments /external entities using standard interfaces/connectors. The gateway acts as the single point of access to backend departments for all external entities. The state level gateway also interacts with the NSDG at the central level for exchange of data with central MMPs.

Implementation guidelines

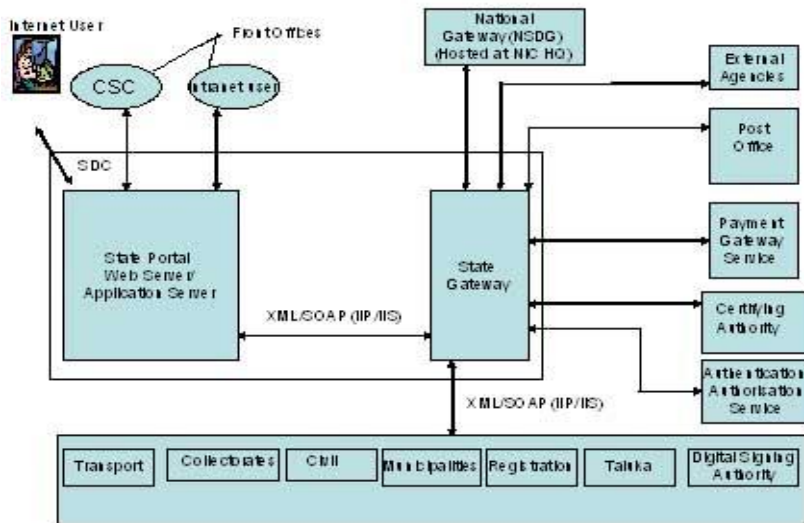

Exhibit 2 – Architecture of SDC

The State Portals will host all the forms for various Government Services accessible to citizens in the state. A citizen will be able to download the forms through the various CSC outlets and submit his/her application electronically. This submitted form will be routed intelligently by the SSDG to the respective field office in the state responsible for providing that particular service. The Gateway will guarantee assured delivery of the request from the citizen to the government department and the acknowledgement of successful submission from department to the citizen. A citizen will be able to query the status of his/her application at a later point in time. This request/ response again will be routed through the SSDG.

The basic functionalities envisaged through SSDG are as follows:

- Act as hub for all the interactions between service seekers (the citizen and businesses) and various service providers (Government Departments) and even among Government Departments.
- Audit Management & Time Stamping - Results in better tracking (auditing) and security of each transaction.

Implementation guidelines

- Web enabling of Legacy Applications - With Gateway Server, legacy applications can be Internet enabled as Gateway server can act as a Web layer around them so Government Departments need to put least effort for web enabling of their legacy applications.
- Interoperability – The gateway as the middleware will facilitate easy inter-departmental data exchange.
- Departmental Workflow - The Gateway will also help the Departments backend workflow evolve gradually as the Gateway acts as a middleware de-linking the backend from the front end. This means that even the Departments, which do not have the complete automation or workflow at the back, can still deliver e-Service to the citizens in a limited manner.
- Seamless availability of information
- Shared Services - In future, Gateway has the capability to add additional functionality to support shared common services like Authentication, payment gateway interface, etc
- Applications developed at the state level can interact with the gateway through connectors. The generic connectors will be provided by C-DAC and the application specific connectors will be developed by the implementation agency for the state.
- The position of the Gateway as the middleware will facilitate easy provisioning of government services through various delivery channels seamlessly.
- The positioning of Gateway Server and building portal of all the departments at Central location, i.e., in SDC, will help in better centralized Administration, Monitoring, over all maintenance work and deployment of hardware of Web Site at optimal level.

7.2.1 SSDG Manuals

The manuals that would be supplied by C-DAC for SSDG would include:-

- Operational manuals: Includes procedures and time lines required to be followed and all the operational details
- User manual: Includes an index to all the manuals, the installation procedure along with the installation manuals for JBOSS, PostgreSQL, GSD, NSD,

Messaging, PKI, How to register services and SAP, Obtaining Digital certificates etc.

- Troubleshooting manuals: All possible problems or errors that one may come across and how to resolve those errors
- Cook-Books: Some scenarios and the connectors for those scenarios
- Connector development manuals : Role of connectors, types of connectors, Java docs, API, inputs and outputs, Sequence diagram of end-to-end working, Testing procedure of the connectors

7.2.2 Registration of Department and Services

The registration process would be carried out for each department, its services and destination offices on SSDG interface.

The various departments would need to be registered with the SSDG Interface. Once the departments are registered, they also need to register all the services provided by the respective department. The various locations which provide the given service also need to be registered with the SSDG Interface with respect to the various services and departments. This registration is done so that the requests for the service (applications from citizens) can be routed to their respective destination offices.

For more information on the registration process please refer SSDG User Manual.

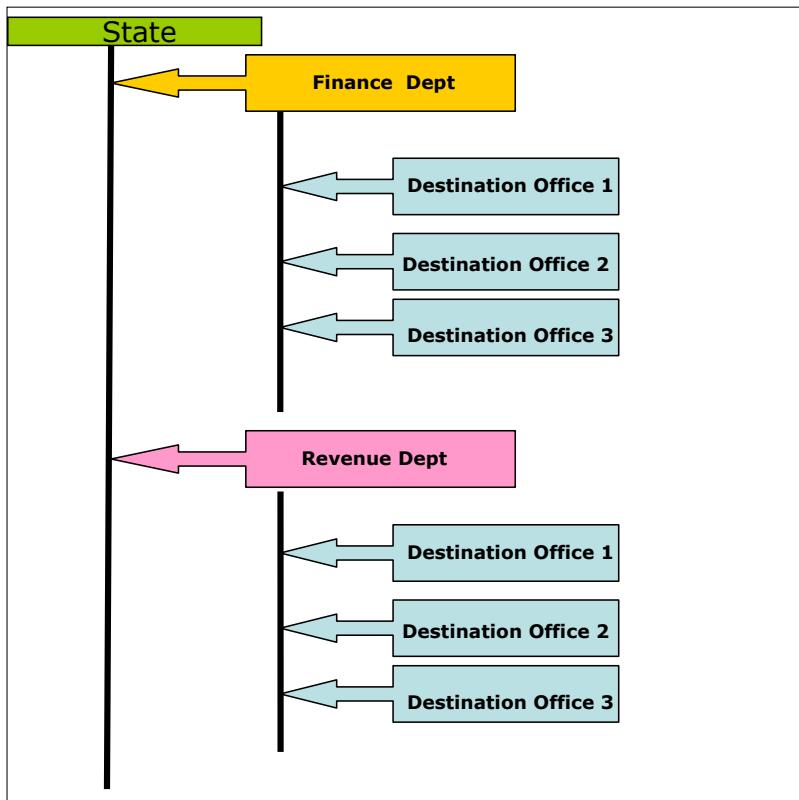

Exhibit 3 – Hierarchy for Departments and Services

7.2.3 Routing of e-Forms by SSDG

Intelligent routing is a mechanism by which e-Forms can be routed automatically to the respective destination offices on the basis of information provided by the citizen in the respective service e-Form. The e-Form design should ensure that the fields needed for routing are captured in the e-Form. Based on the information available as a result of the registration of the department, service and

Implementation guidelines

| State | Department | Service | District | Tehsil/Taluk |
|---------|-------------------|---------|----------|--------------|
| State 1 | Revenue | S 1 | D 1 | T 1 |
| | | S 2 | | T 2 |
| | | . | | |
| | | . | | |
| | | . | D 2 | . |
| | | S n | . | T n |
| | | . | . | . |
| | | . | D n | . |
| | Finance | | | |
| | Rural Development | | | |
| | IT | | | |
| | Fisheries | | | |

field offices with SSDG, the e-Form would be routed to the respective

department/service/destination offices.

For example, in the case of Domicile certificate, the e-Form will be automatically routed to the destination office on the basis of the information provided in the permanent address by the citizen. Citizens are not required to provide any extra information for the routing purpose as this will be handled by the gateway automatically. The officer at the destination office receives the routed e-Form request for the further processing. Officer verifies the data which citizen has provided and acknowledges the response to that request.

States need to prepare a routing pattern as shown below. This will help in routing the services to the respective destination offices. The department, services and field offices would be registered with SSDG based on this table. Subsequently when an e-Form for this service of the department is submitted on the state portal and received at SSDG, based on the destination in the address field in the e-Form the form is routed to the correct field office.

Exhibit 4 – Routing Table

7.3 e-Forms application

The e-Forms application consists of two components namely:-

- a) Front end component
- b) Back end component

It is proposed to host e-Forms (front end component) on State Portal. The e-Forms designed using e-Forms designer tool would be hosted on State Portal and would be downloaded by citizen for the purpose of online and offline submission. Once the submission of e-Form is done to the State Portal, the e-Form data will be routed by SSDG to the respective Department Server (DS) (Centralized application in the case of non automated departments and services- backend component of the application) where information filled by citizen will be stored. Service locations of the departments will pull the information from the DS and after processing, will submit response to State Portal via SSDG. Citizen will get periodic status update on State Portal. The backend of the e-Forms application may be a single component (centralized application) or comprised of multiple units (multiple departmental applications or servers). The different architectures for the backend application are discussed in section 8 Integration with other MMP's.

Implementation guidelines

The figure given below gives the architecture of the system with all the components put together.

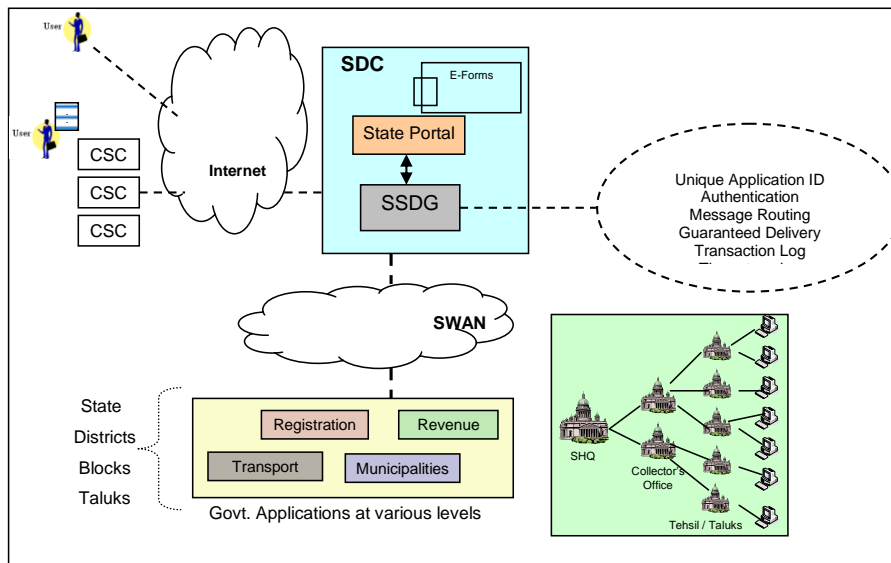

Exhibit 5 – Architecture of the System

7.3.1 e-Forms Standards (Meta data Standards)

The e-Forms should adhere to the Metadata standards defined by the standards group and notified by DIT.

Metadata is structured information that describes, explains, locates or otherwise makes it easier to store, retrieve, use or manage an information resource. Metadata is often called data about data or information about information.

Advantages of using Metadata Standards

In the e-Forms application, Metadata standards have an important part to play. A Metadata driven e-Form would provide following advantages:

Implementation guidelines

- High degree of inherent consistency across forms
- Eliminating redundancy
- An opportunity to reorganize the government's data collection activities
- Promoting data sharing
- Facilitating components based architecture
- Promoting 'Reuse & Harmonization' across forms
- Reducing reporting burden

Standards for localization and Metadata and Data Standards have been notified by DIT in the official gazette of India and are available at the website www.egovstandards.gov.in.

8 Integration with other MMPs

The various Central and State Mission Mode Projects (MMPs) under the NeGP are under different phases of project conceptualization, design and implementation stage. The idea is to develop a framework for speedy realization of benefits under NeGP, and in a way such that the various other MMPs can utilize this framework as and when they are in operational phase. The following three scenarios will explain e-Forms integration with other MMPs.

8.1 Scenario 1 – State Department with Non - Automated Backend IT System

Implementation guidelines

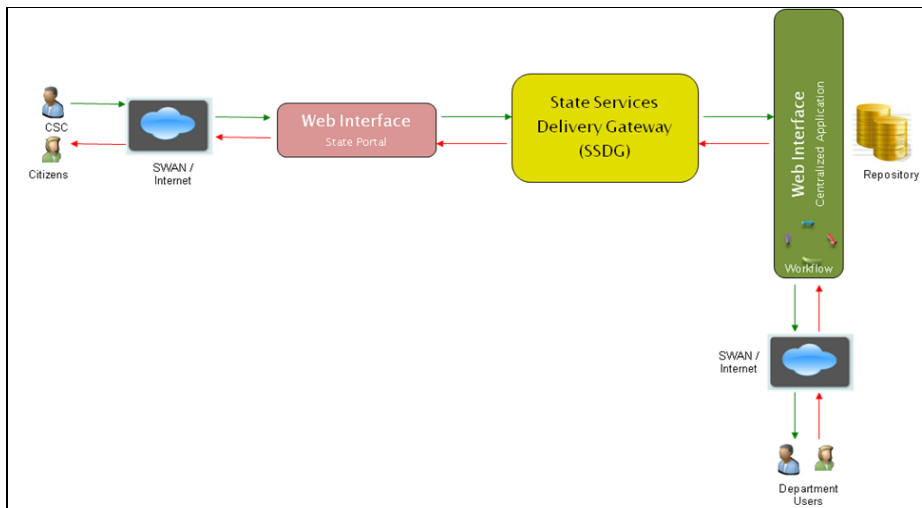

Exhibit 6 – Scenario 1 - Integration Framework of e-Forms with Non Automated departments

As depicted in the solution architecture above, the proposed solution shall consist of three components.

- a) The State portal including applications and electronic forms
- b) The State Services Delivery Gateway
- c) The Centralized Application

The State portal including applications and electronic forms:-Please refer section 7.1 i.e., State Portal of this document.

The State Services Delivery Gateway [SSDG]:-Please refer section 7.2 i.e., State Services Delivery Gateway of this document.

Centralized Application: - Please refer section 13.6.2 i.e. e-Form PoC Architecture

The above architecture explains the e-Forms integration with SSDG where the back-end application is non-automated in the State. The e-Forms will be hosted on State Portal for e-filing. Citizens will access these e-Forms through internet or they can directly go to nearest

Implementation guidelines

CSC office where the operator will access these e-Forms through internet or SWAN. The e-Forms are available in both online and offline mode for future filling of information. Once the application form is submitted from the portal, it will be processed into an IIP/IIS compliance message structure. This message is then routed to SSDG by using the required adapters (connectors).

SSDG will intelligently route the message onto the centralized application by calling the required adapters. The departments will be connected through SWAN or internet and the department users will login into this application and process the various services. The acknowledgement is received from this centralized application and routed to the State Portal for delivery to the citizen.

8.2 Scenario 2 – State Department with Automated Backend IT System

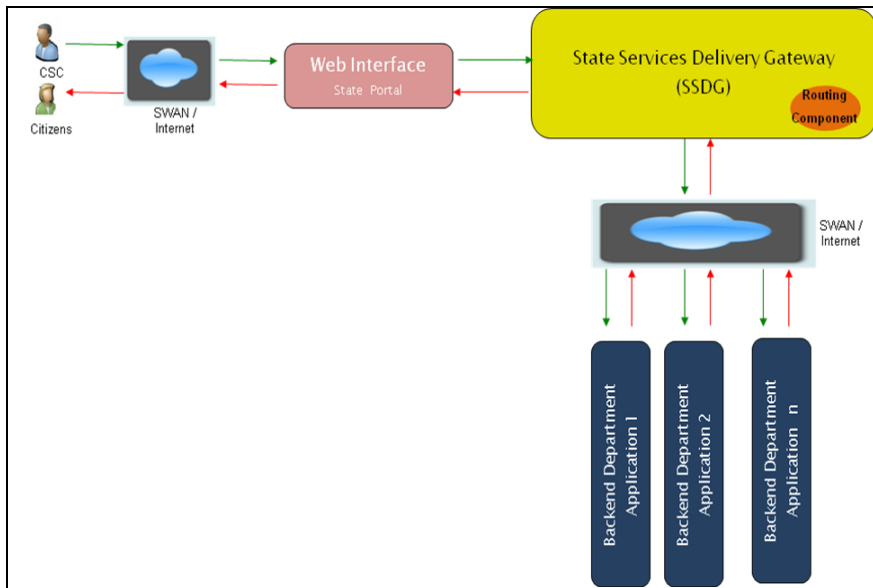

Exhibit 7 – Scenario 2 - Integration Framework of e-Forms portal with Automated Backend Services

Implementation guidelines

The above architecture explains the e-Forms integration with SSDG where the back-end application is fully automated in the State. The e-Forms will be hosted on State Portal for e-filling. Citizens will access these e-Forms through internet or they can directly go to nearest CSC office where the operator will access these e-Forms through internet or SWAN.

SSDG will routes the message onto the back-end department's system by calling the required adapters. The different departments will be connected through SWAN or internet. The acknowledgement is received from the back-end department and routed to the State Portal for delivery to the citizen.

8.3 Scenario 3 - State Department with Partially Automated Backend IT System

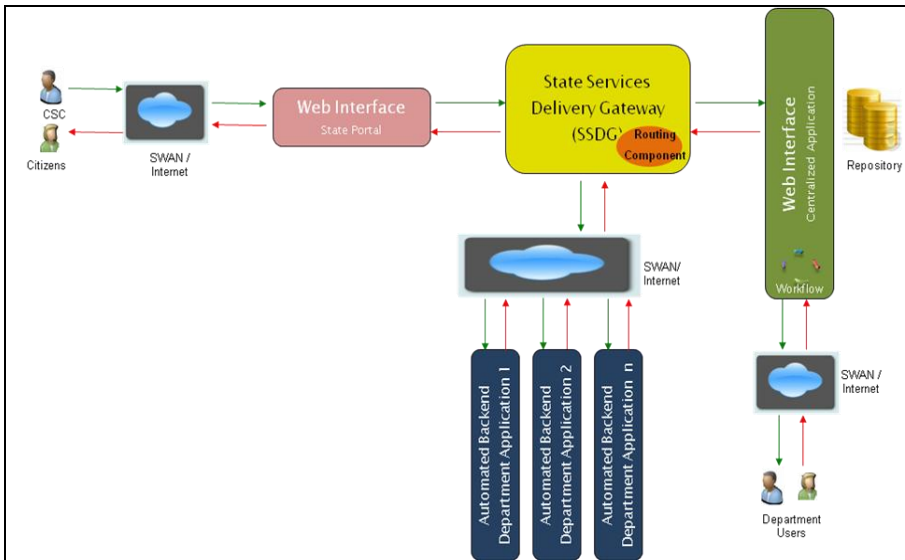

Exhibit 8 – Scenario 3 - Integration Framework of e-Forms portal with Partially Automated Backend Services

The above architecture explains the e-Forms integration with SSDG where the back-end application is partially automated i.e., some services in the State have automated backend

Implementation guidelines

application where as others are not. The e-Forms will be hosted on State Portal for e-filing. Citizens will access these e-Forms through internet or they can directly go to nearest CSC office where the operator will access these e-Forms through internet or SWAN. SSDG will intelligently route the message onto the back-end department's system by calling the required adapters. The automated departments will be connected through SWAN or internet. The acknowledgement is received from the back-end department and routed to the State Portal for delivery to the citizen.

For the non-automated departments, the application will be routed onto the centralized application. These departments will be connected through SWAN or internet and the department users will login into this application and process the various services. The acknowledgement is received from the back-end department and routed to the State Portal for delivery to the citizen.

9 Acceptance Criteria

The acceptance criteria are to be detailed on the below listed topics:-

- The portal has been developed according to the guidelines of the SPF.
- The e-Forms application is in accordance with the architecture described above and communicates with the backend application (centralized application) via the SSDG gateway.
- Existing e-District application (if any in the state) should be integrated with the e-Forms application and SSDG.
- Training has been imparted and feedback evaluated to ensure that the effectiveness of the training is above the defined percentage.
- Identified gap infrastructure has been made available.
- The states shall define the Acceptance Criteria as the exact name and number of services to be delivered at an exact number of locations the following table may be used for this purpose.

Implementation guidelines

| S. No. | Service Name | Locations for this service | Dependency on Government order / decision? If YES, specific plan to address the dependency? |
|---------------|---------------------|-----------------------------------------------------------|-----------------------------------------------------------------------------------------------------|
| 1 | <<Service Name1>> | <<Location 1>> <<Location 2>> ... <<Location n>> | <<Information about Govt. Order, Power and / or Connectivity, etc. to be addressed by Govt. Dept.>> |
| | | | |
| 2 | <<Service Name2>> | <<Location 1>> <<Location 2>> ... <<Location n>> | |
| ... | ... | ... | ... |
| N | <<Service NameN>> | <<Location 1>> <<Location 2>> ... <<Location n>> | |

10 Checklist

| S.No | Description | Completed Yes/No | Reason if answer is No |
|------|-------------------------------------------------------------------------------------------------------------|------------------|------------------------|
| 1 | Nodal Agency identified | | |
| 2 | Services prioritized as per guidelines | | |
| 3 | Formalized arrangement with the departments concerned, regarding processing of electronic requests received | | |
| 4 | State Implementation Committee for the project formed. | | |
| 5. | Engagement of STQC done for the project. | | |
| 6. | Consultant selected. | | |
| 7. | RFP floated. | | |
| 8. | Implementation Agency selected. | | |
| 9 | | | |
| 10 | | | |

11 Helpdesk

11.1 Contact Information

11.1.1 DIT, NIC and CDAC contacts

| Entity | Name of Contact | Telephone | E-mail | Address |
|--------|-----------------|----------------------------------|-----------------------|--------------------------------------------------------------------------------|
| DIT | Renu Budhiraja | +91-01124363132 +919871091515 | renu@mit.gov.in | Room No. 3078,Electronics Niketan 6 CGO Complex Lodhi Road New Delhi-110003 |
| DIT | Bhushan Mohan | +91-01130481614 +919810266016 | bmohan@negp.gov.in | PMU NeGP,Electronics Niketan 6 CGO Complex Lodhi Road New Delhi-110003 |
| DIT | Kavita Bhatia | +91-01124364729 +919818193281 | kbhatia@mit.gov.in | Room No. 2019,Electronics Niketan 6 CGO Complex Lodhi Road New Delhi-110003 |
| NIC | Neeta Verma | 24363692 +919811299934 | neeta@nic.in | NIC Hqrs, 3rd Floor CGO Complex Lodhi Road New Delhi-110003 |
| NIC | Alka Mishra | +91-01124305395 9868253876 | amishra@nic.in | NIC Hqrs, 3rd Floor CGO Complex Lodhi Road New Delhi-110003 |
| C-DAC | Zia Saquib | +91-02226201606 +91982143364 | saquib@cdacmumbai.in | C-DAC, Mumbai, Gulmohar Cross Road No.9, Juhu, Mumbai 400 049 |
| C-DAC | Padmaja | +91-02226201606 | padmaja@cdacmumbai.in | C-DAC, Mumbai, Gulmohar Cross Road No.9, Juhu, Mumbai 400 049 |

Appendix

12 Terminology

12.1 Acronyms

| Abbreviation | Full Form |
|--------------|---------------------------------------------------|
| RFP | Request For Proposal |
| DIT | Department of Information Technology |
| SSDG | State Service Delivery Gateway |
| UT | Union Territory |
| FRS | Functional Requirements Specification |
| e-Forms | Electronic Forms |
| CSC | Common Service Center |
| SWAN | State Wide Area Network |
| SDC | State Data Center |
| STQC | Standardization Testing and Quality Certification |
| SAP | Service Access Provider |
| SP | Service Provider |
| C-DAC | Center for Development of Advanced Computing |

12.2 CSC

The Government has approved a Common Services Centers (CSCs) Scheme for providing support for establishing 100,000 Common Services Centers in 600,000 villages of India. The Scheme, as approved by the Government of India, envisions CSCs as the front-end delivery points for Government, private and social sector services to rural citizens of India, in an integrated manner. The objective is to develop a platform that can enable Government, private and social sector organizations to align their social and commercial goals for the benefit of the rural population in the remotest corners of the country through a combination

Implementation guidelines

of IT-based as well as non-IT-based services. Now the goal has been revised to set up 2,50,000 CSC's across the country.

The CSC Scheme has a 3-tier implementation framework:

- At the first (CSC) level would be the local Village Level Entrepreneur (VLE- loosely analogous to a franchisee), to service the rural consumer in a cluster of 5-6 villages.
- At the second/middle level would be an entity termed the Service Centre Agency (SCA loosely analogous to a franchiser) to operate, manage and build the VLE network and business. An SCA would be identified for one or more districts (one district would cover 100-200 CSCs).
- At the third level would be the agency designated by the State- the State Designated Agency (SDA) - to facilitate implementation of the Scheme within the State and to provide requisite policy, content and other support to the SCAs.

12.3 SWAN

The SWAN Scheme for 29 States & 6 Union Territories was approved by Govt. of India, in March 2005 to set up State Wide Area Networks (SWAN), interconnecting each State / UT Head Quarter with District Head Quarter and below each District Head Quarter with the Block Head Quarters with minimum 2 Mbps leased line.

The objective of the Scheme is to create a secure close user group (CUG) government network for the purpose of delivering G2G and G2C services. The duration of project is 5 years with a pre-project implementation period of 18 months.

12.4 SDC

State Data Centers are proposed to be established across 29 States and 6 UTs in the country in order to provide shared, secured and managed infrastructure for consolidating and securely hosting State level data and applications. SDC would provide better operations and management control and minimize overall cost of Data Management, IT management, deployment etc. SDCs would ordinarily be located at the State Headquarters and help the state Government State Line Ministries and Departments in providing central repository (database consolidation), application consolidation, State Intranet/Internet portal, State messaging infrastructure, remote management, business continuity site etc. needed for their

Implementation guidelines

G2G, G2C and G2B services. The various Mission Mode Project (MMPs), both at the central level, State level and also the integrated services of the NeGP are expected to use SDCs to deliver their services.

12.5 India Portal

India Portal is a Mission Mode Project in the integrated services category under the NeGP being implemented by NIC. The MMP is to Create a Unified portal providing 'single window access' to information and G2C services to be electronically delivered from all state sector institutions and organizations. The First version of Portal is operational now and was released by Hon'ble MCIT on 10th Nov'2005 and the portal address is <http://india.gov.in/>. The main sections of the portal include Government corner, Citizen, Business, Oversees, Know India, Government services, Content repositories (Forms, Documents, Maps), sectors, Tenders etc. National Portal Coordinators (NPCs) have been identified from 35 states and 66 Central Ministries/ Dept. who are responsible for the content development, compilation and maintenance. A web based Content Management System (CMS) interface has been developed to facilitate the contribution of government information & services on to the National Portal by NPCs. The Hindi version of the India Portal is available and the other language would follow subsequently. There has been an attempt by the National Portal to bring together all online services offered by the Central and State Government under a single umbrella for different categories of services like G2G, G2E, G2C and G2B. Around 1500 services offered by different State Governments have been added. About 800 new rules and 1300 Acts of different State have been contributed to the National Portal and 4500 forms are published on the Portal.

13 Annexure

13.1 Annexure I -List of empanelled Implementing Agencies with their contact details

In order to expedite the implementation of this project at state level, DIT has empanelled following agencies as Implementing Agencies:

| S.No | IA Name | Name of Contact | Telephone | E-mail |
|------|-------------|-----------------------------------|--------------------------------------|-------------------------------------------------------------------------------------|
| 1 | 3i Infotech | Saroj Das | +91-0120-3323200 | saroj.das@3i-infotech.com |
| 2 | Accenture | G Sethuraman | +91 80 4052 6813, +91 98451 18940 | g.sethuraman@accenture.com |
| 3 | HP Sales | Som Satsangi Amit Krishna | +91-124-2566111 +91-9810083124 | som.satsangi@hp.com amit.krishna@hp.com |
| 4 | Infosys | Navneet Taneja Saroj Senapathy | +91-9711005826 +91-080-39132053 | navneet_taneja@infosys.com sarojks@infosys.com |
| 5 | Wipro | Manish Kumar | +91124-3084384 | manish.mkmar@wipro.com |

13.2 Annexure II --List of empanelled Consulting Agencies with their contact details

In order to assist the state in preparing the RFP and in supervising the implementation of this project, DIT has empanelled following agencies as Consulting Agencies

| S.No | IA Name | Name of Contact | Telephone | E-mail | Address |
|------|---------------|---------------------------------|------------------------------------|-----------------------------------------------------|--------------------------------------------------------------------------------------------|
| 1 | Ernst & Young | Meghna Shrimali Guru Malladi | +91-9871193248 +91-124-464-4188 | Meghna.Shrimali@in.ey.com Guru.Malladi@in.ey.com | Golf View Corporate Tower B,Near DLF Golf Course, Sector 42,Sector Road, Gurgaon – 122002. |

Implementation guidelines

| | | | | | |
|---|--------|-------------------------------|-----------------------------------|----------------------------------------------------------|-----------------------------------------------------------------------------------------------------------------------------|
| 2 | IL&FS | Dinesh Tyagi, Rajiv Aggarwal | +91-124-471-6576 | dinesh.tyagi@ilfsinda.com rajiv.aggarwal@ilfssets.com | IL&FS Ltd., Ambience Mall, Ambience Corporate Tower (3rd Floor), National Highway No.8, Gurgaon, Haryana – 122001 |
| 3 | KPMG | Vikas Aggarwal, Navin Agrawal | +91-9871291918 +91-22-39836401 | vikasa@kpmg.com navinagrawal@kpmg.com | KPMG Advisory Services Pvt. Ltd., KPMG House, Kamala Mills Compound, 448, Senapati Bapat Marg, Lower Parel, Mumbai – 400013 |
| 4 | PWC | Ramendra Varma, Neel Ratan | +91-9811201269 +91-124-4620510 | ramendra.verma@in.pwc.com neel.ratan@in.pwc.com | PricewaterhouseCoopers Private Limited, Building-8, Tower-B, 7th and 8th floor, DLF Cyber City, Gurgaon – 122002 |
| 5 | UTITSL | Deepak Kumar | +91-22-67931106 | deepak.kumar@utitsl.co.in | UTI Technology Services Limited Plot No. 3 Sector 11 CBD Belapur, Navi Mumbai – 400614 |

13.3 Annexure III – Chronological list of E-Form, State Portal SSDG Activities

| No. | Steps |
|-----|-----------------------------------------------------------------------------------------------|
| 1 | Scheme Approval |
| 2 | Letters to states to identify departments for e-enablement, gaps at field offices and costing |
| 3 | Letter to states to send project proposal to DIT and prepare for e-Forms submission |
| 4 | Project Proposal by states to DIT and subsequent approval |
| 5 | Funding sanction for states |

Implementation guidelines

| | |
|----|-------------------------------------------------------------------------------------------------------------------------------------------------------------------------------------------------------------------------------------------------------------------------------------------------------------------------------------------------------------------------------------------------------------------------------------------------------------------------------------------------------------------------------------------------|
| 6 | Identification of Forms for conversion to e-Forms as a part of PoC |
| 7 | Conversion of above Forms into e-Forms |
| 8 | Implementation of e-Form PoC using the e-form portal by CDAC / India Portal and NSDG in 4 states |
| | <ol style="list-style-type: none">1. Validation of the common Forms used under the PoC by Tamil Nadu, WB, Maharashtra and Kerala and incorporation of Metadata2. Implementation of updated Forms and State specific repository for 4 states by CDAC. Setup of e-Forms website3. Meeting with the States for PoC (States buy-in for the Form Engine and PoC)4. Integration of NSDG with India Portal5. Launch of the e-Form PoC and Engine6. Hosting of these e-Forms on India Portal |
| 9 | Utilization of e-Forms by other State Govts through NSDG |
| 10 | RFP for Empanelment of Implementing Agencies |
| 11 | Empanelment of Implementing Agencies at DIT GoI |
| 12 | RFP for empanelment of Consultants |
| 13 | Empanelment of Consultants |
| 14 | Selection of consultant by states |
| 15 | Preparation of RFP by states |
| 16 | States float RFP for selection of implementation agency |
| 17 | Selection of Implementing Agencies by states with consultant assistance |
| 18 | Implementation of e-Forms by Cat A States |
| 19 | Implementation of e-Forms by Cat B States |
| 20 | Implementation of e-Forms by Cat C States |
| 21 | Implementation of e-Forms by Cat D States |
| 22 | Training by CDAC/NIC/IA for SSDG and portal and eforms application |
| 23 | UAT by STQC |

13.4 Annexure IV --List of identified 40 e-Forms

| Prioritized List of Services | | | | | |
|------------------------------|-----------------------------------------------------------------------|-----------------------|-------------------------------------|-------------------------------------|-------------------------------------|
| Sr.No | Services List | Department | High Volume | High Citizen Outlook | MMP Services |
| | CERTIFICATES | | | | |
| 1. | Caste Certificate - SC/ST/ OBC | Revenue | <input checked="" type="checkbox"/> | <input checked="" type="checkbox"/> | |
| 2. | Birth Registration | Health / Municipality | <input checked="" type="checkbox"/> | <input checked="" type="checkbox"/> | |
| 3. | Birth Certificate - [Addition of name/Change in Name/Late entry case] | Health / Municipality | <input checked="" type="checkbox"/> | <input checked="" type="checkbox"/> | |
| 4. | Death Registration | Health / Municipality | <input checked="" type="checkbox"/> | <input checked="" type="checkbox"/> | |
| 5. | Death Certificate [Normal/Late Entry cases] | Health / Municipality | <input checked="" type="checkbox"/> | <input checked="" type="checkbox"/> | |
| 6. | Non-Encumbrance | Revenue | | <input checked="" type="checkbox"/> | |
| 7. | Residence Certificate | Revenue | | <input checked="" type="checkbox"/> | |
| 8. | Domicile Certificate | Revenue | <input checked="" type="checkbox"/> | <input checked="" type="checkbox"/> | |
| 9. | Handicap Certificate | Revenue | | | |
| 10. | Income Certificate | Revenue | <input checked="" type="checkbox"/> | <input checked="" type="checkbox"/> | |
| 11. | Solvency Certificate | Revenue | | | |
| | REVENUE | | | | |
| 12. | ROR / Certified copies of ROR | Revenue | | | <input checked="" type="checkbox"/> |
| 13. | Permission for Loudspeaker | Revenue | | <input checked="" type="checkbox"/> | |
| 14. | Permission for Fair | Revenue | | <input checked="" type="checkbox"/> | |
| 15. | Permission for processions | Revenue | | <input checked="" type="checkbox"/> | |

Implementation guidelines

| Prioritized List of Services | | | | | |
|------------------------------|----------------------------------------------------------|--------------|-------------------------------------|-------------------------------------|-------------------------------------|
| Sr.No | Services List | Department | High Volume | High Citizen Outlook | MMP Services |
| | MARRIAGE SERVICES | | | | |
| 16. | Registration under Hindu Marriage Act | Revenue | <input checked="" type="checkbox"/> | <input checked="" type="checkbox"/> | <input checked="" type="checkbox"/> |
| 17. | Registration of Marriage under special Marriage act | Revenue | <input checked="" type="checkbox"/> | <input checked="" type="checkbox"/> | |
| 18. | Issuance of Marriageability certificate | Revenue | | | |
| 19. | Solemnized marriage | Revenue | | <input checked="" type="checkbox"/> | |
| | ELECTORAL SERVICES | | | | |
| 20. | Issuance of Voter Certificate / iCard | Election | <input checked="" type="checkbox"/> | <input checked="" type="checkbox"/> | |
| 21. | Duplicate Voter Certificate / iCard | Election | <input checked="" type="checkbox"/> | <input checked="" type="checkbox"/> | |
| 22. | Application for inclusion of name in the electoral rolls | Election | <input checked="" type="checkbox"/> | <input checked="" type="checkbox"/> | |
| 23. | Application for Deletion of Name in the Voter's List | Election | <input checked="" type="checkbox"/> | <input checked="" type="checkbox"/> | |
| | UTILITY SERVICES | | | | |
| 24. | Application for electricity connection | Municipality | <input checked="" type="checkbox"/> | <input checked="" type="checkbox"/> | |
| 25. | Application for Water connection | Municipality | <input checked="" type="checkbox"/> | <input checked="" type="checkbox"/> | |
| 26. | Application for Telephone connection/Transfer | Municipality | <input checked="" type="checkbox"/> | <input checked="" type="checkbox"/> | |

Implementation guidelines

| Prioritized List of Services | | | | | |
|------------------------------|-------------------------------------------------------------------------------|-----------------|-------------------------------------|-------------------------------------|-------------------------------------|
| Sr.No | Services List | Department | High Volume | High Citizen Outlook | MMP Services |
| 27. | Application for Sewerage connection | Municipality | <input checked="" type="checkbox"/> | | |
| | LICENSES | | | | |
| 28. | Issuance of Arms License | GAD | | <input checked="" type="checkbox"/> | |
| 29. | Renewal of Arms License | GAD | | <input checked="" type="checkbox"/> | |
| | EDUCATION | | | | |
| 30. | Application for Scholarship Programs- [Merit/Caste/Financial Status oriented] | Education | | <input checked="" type="checkbox"/> | |
| | EMPLOYMENT | | | | |
| 31. | Registration with Employment Exchange | Employment | | <input checked="" type="checkbox"/> | |
| | SOCIAL WELFARE | | | | |
| 32. | Pension- Widow | Social Welfare | <input checked="" type="checkbox"/> | <input checked="" type="checkbox"/> | <input checked="" type="checkbox"/> |
| 33. | Pension- Old Age | Social Welfare | <input checked="" type="checkbox"/> | <input checked="" type="checkbox"/> | |
| 34. | Pension- Physically Handicapped | Social Welfare | <input checked="" type="checkbox"/> | | |
| 35. | Issue of New Ration Card | Food & Supplies | <input checked="" type="checkbox"/> | <input checked="" type="checkbox"/> | |
| 36. 36 | Duplicate Ration Card | Food & Supplies | <input checked="" type="checkbox"/> | <input checked="" type="checkbox"/> | |
| 37. 37 | Modification in Ration card - Addition/Deletion/ Change of Address | Food & Supplies | <input checked="" type="checkbox"/> | <input checked="" type="checkbox"/> | |

| Prioritized List of Services | | | | | |
|------------------------------|--------------------------------------------------------|-----------------|-------------------------------------|-------------------------------------|--------------|
| Sr.No | Services List | Department | High Volume | High Citizen Outlook | MMP Services |
| 38. 38 | Surrender Certificate against Ration Card | Food & Supplies | | <input checked="" type="checkbox"/> | |
| | RIGHT TO INFORMATION ACT | | | | |
| 39. 39 | Application for Appeal Registration & Appeal Redressal | All Departments | | <input checked="" type="checkbox"/> | |
| | GRIEVANCE | | | | |
| 40. 40 | Grievance Service | All Departments | <input checked="" type="checkbox"/> | <input checked="" type="checkbox"/> | |

13.5 Annexure V- Service Delivery Models

Different states will have different mechanisms to process any service; it is up to state to follow any one of these delivery models. These delivery models provide various options to States at four different levels. State may select any of the option provided they issue the adequate Government Orders (GOs) for the same. The states also need to have controls and implementation mechanism in place. Various options available with the states are as indicated below:

1. Submission of e-Form Application- The e-Forms would be available to be filled in both online and offline modes and the application would be submitted when user is online. Citizen can either access these e-Forms via internet or approach the nearest CSC.
2. Supporting documents- The supporting documents can be submitted by following means:-
 - a. Citizen can take the printout of the submitted application, attach all the documents with the form and send it to the correspondence address provided by the department.
 - b. Citizen can also give these documents to the CSC operator and the operator can forward these documents to the department concerned.

Implementation guidelines

- c. Citizen can scan the supporting documents and upload online with the application.
 - d. Citizen can show the supporting documents in person to department concerned at the scheduled time.
 - e. CSC operator can be authorized to verify original documents before submitting the online application or before handing over the certificate to the citizen.
 - f. The citizen will be asked to present the original supporting documents at the time of field enquiry.
3. Certificate- The certificate can be delivered via the following modes:-
- a. Certificate can be sent directly to the citizen either by post or courier to the address mentioned in the application.
 - b. Certificate can be delivered electronically with Digital Signatures on it directly to citizen or to CSC's email account. This option can be used wherever the facility has been put in place and relevant orders issued.
 - c. Services which are not critical can be delivered without signatures. State need to issue the GOs for the same. The certificates would be marked as electronic copy and an alternative method defined to obtain the original if needed for any purpose.
 - d. CSC operator may be authorized to deliver the original certificate after the verification.
 - e. CSC operator is authorized to sign the certificate for non critical services but the state need to issue the GO's for the same.
4. Application fee- The state would fix a fee for the services provided through the CSC by the following means:
- a. Indian Postal Order
 - b. Demand Draft
 - c. Court fee stamps
 - d. Non-judicial stamps
 - e. Introduce e-Service Postal envelopes, which would have an inbuilt cost of application fee in common denominations.
 - f. Facilitate payment through Electronic Payment Gateway while submitting application on the web.

Note: - State would not be liable for the payment gateway. There should be a mutual agreement between the various departments and the service providers.

13.6 Annexure VI – e-Forms PoC by CDAC and Learnings

13.6.1 PoC overview

The e-Forms PoC project was initiated by DIT and C-DAC was the agency selected for the implementation. The scope of Phase I of the PoC was

- a. Customization of C-DAC's e-Form Product "Fulcrum" to current requirements
- b. e-Form creation for 40 services
- c. To validate the forms and get the PoC done on C-DAC e-Form technologies
- d. Integration of e-Forms with India Portal, NSDG and Demo SP
- e. Architecture Design for Integration with Other MMPs using e-District as a reference.

13.6.2 e-Form PoC architecture

In the e-Forms PoC, the e-Forms developed were hosted on the website e-Forms.gov.in and NSDG was used as the gateway. The backend of the application consisted of a centralized application.

Centralized Application

The Centralized Application served as the backend application for all the departments to receive and process the information / applications received via NSDG from the e-Forms application frontend. The centralized application provided the following functionality:-

- **Centralized Data Repository:** The Centralized application was a centralized data repository for the field offices of the various departments identified under the project. The submitted e-Forms along with the required attachments are stored in designated

Implementation guidelines

specific data stores. The officers from the various field offices can access the central application by providing their access credentials. The compartmentalized central database will provide for the required role based access control mechanisms to ensure that departmental data remains specific to a department user and is not shared across departments or given to unauthorized users.

- **User Authentication & Role based access control:** The users from various backend departments shall be provided with access credentials governed by a comprehensive role based access control mechanism. This will ensure that only authenticated and authorized users are allowed to access the data in the back end system.
- **Workflow Services:** The central application was equipped with a workflow engine to enable departments to create simple workflows for the processing of various applications received from the State Portal.
- **MIS & Status Reporting:** Reporting of details related to the applications received and processed were generated from the Central Application.

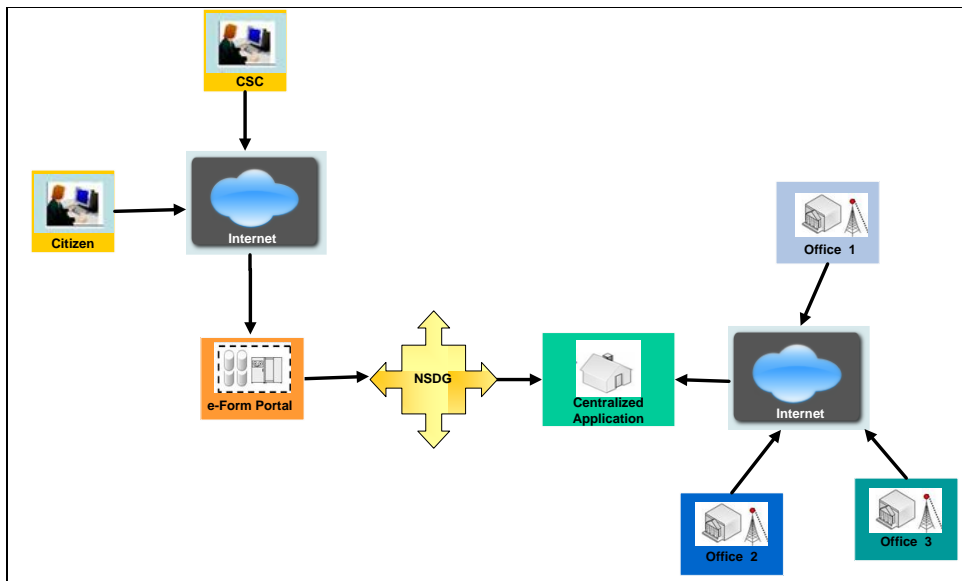

Exhibit 9 – e-Form PoC Architecture

13.6.3 E-Form design

During e-Forms PoC project, it was observed that many data fields in the forms were getting repeated. Therefore, it was decided that the e-Forms would be designed in such a manner that the citizen is not required to provide the repetitive information again & again. Thus, in the e-Form PoC the e-Form was divided into two parts, but States may customize and enhance these e-Forms according to their requirements.

a) Registration Form (Part I)

Registration Form for the e-Forms contains the identity related details of the applicant. All the data of the applicant in Part I is either static or consist of those elements, which will be changed occasionally. The basic information about citizen captured in registration form like applicant's name, father's name, date of birth, gender, caste, religion, address, etc will be stored in a repository. Part I is designed by analyzing the data fields present in the physical copy of the service request forms. After the detailed

Implementation guidelines

assessment, 15 data fields were short listed which were common across most of the services.

Every applicant need to register with the e-Form Portal and provide his/her (Part I) details only once during the first time registration. After submitting Part I details, the system would generate a unique "Registration ID" for future reference which will be used in other services e-Forms to be submitted by the applicant later on. Once the system has generated the "Registration ID", the applicant would be required to use the same ID for all the services. The data fields in Part I can be multilingual with an aim to provide ease to the applicant.

| Field Name | Entry Section |
|--------------------------------------------|----------------------------------------------------------------------------------------------------------------------------------------|
| Full Name of the Applicant * | <input type="text"/> |
| Short name of the Applicant * | <input type="text"/> |
| Father's/Husband's/Local Guardian's Name * | <input type="radio"/> Father's Name <input type="radio"/> Husband's Name <input type="radio"/> Guardian's Name <input type="text"/> |
| Mother's Name | <input type="text"/> |
| Date of Birth * | <input type="text"/> <input type="button" value="Calendar"/> |
| Gender Identification * | <input type="radio"/> Male <input type="radio"/> Female <input type="radio"/> Transgender |
| Caste Category | <input type="text" value="Select a choice"/> |
| Religion * | <input type="text" value="Select a choice"/> |
| Marital Status * | <input type="text" value="Select a choice"/> |
| Visible Identification mark * | <input type="text"/> |
| Education Attained * | <input type="text" value="Select a choice"/> |
| Occupation * | <input type="text" value="Select a choice"/> |
| Nationality * | <input type="text"/> |
| <u>Present Address</u> | |
| State * | <input type="text" value="Select a choice"/> |
| District * | <input type="text" value="Select a choice"/> |
| Sub - district/Tehsil/Taluk * | <input type="text" value="Select a choice"/> |

Exhibit 10 – Screen shot of the Registration Form

b) Single Form for Services (Part II)

Single Form : This e-Form contains service specific fields and the identity details of the citizen. Before filling the Single Form for a service, the applicant is required to provide his/her Registration ID.

The screenshot shows a web interface titled "Certificates". Below the title, there is a form with two input fields. The first field is labeled "Enter ApplicantId *" and is empty. The second field is a dropdown menu currently showing "Maharashtra IncomeCertificate". Below these fields is a "GO" button.

Exhibit 11 – Screen shot for entering the Registration ID

The system will automatically obtain the applicant’s identity details from the database which have been already provided in Registration Form. For all services, e-Forms would contain the "Registration ID" field to be filled by the applicant. The concept of “Registration ID” would help in mapping identity details of applicant with the service specific information being submitted by the applicant. Similar to Registration Form, Single Form for the service will also be multilingual.

The screenshot shows a form titled "Income Certificate" with the subtitle "[Single form for Income Certificate for Maharashtra]". The form is divided into two columns: "Field Name" and "Entry Section".

| Field Name | Entry Section |
|-------------------------------------------------------------------------------------------------------------------------------------|---------------|
| Registration ID * नोंदणी क्रमांक * | 11111153125 |
| Unique ID अद्वितीय क्रमांक | |
| Full Name of the Applicant * अर्जदाराचे संपूर्ण नाव * | mohsin |
| Present Address (कायमचा पत्ता) | |
| Name of the State राज्य | Maharashtra |
| District * जिल्हा * | Buldhena |
| Sub-district/Tehsil/Taluk * तालुका / तहसील * | Mehkar |
| Town/City/Village * शहर / गाव * | asdf |
| Locality/Area Name/Post Office * गावठाणेचे नावनाम / पोस्ट ऑफिस * | asdf |
| Block No/Block Name/Street No/Street Name/ Sector No ब्लॉक क्रमांक / ब्लॉक नाव / क्षेत्र क्रमांक / रस्ता क्रमांक / रस्त्याचे नाव | asdf |
| House No/Door No/Flat No/ Building No/Building Name/Lift No * घर क्रमांक / दारवाज क्रमांक / इमारतीचे नाव * | asdf |
| Pin code * पिन कोड * | 123123 |
| Permanent Address (कायमचा पत्ता) | |
| Name of the State राज्य | Maharashtra |

Exhibit 12 – Screen shot for Filling the Income Certificate

Implementation guidelines

District *
जिल्हा * Parbhani

Sub-district/Tehsil/Taluk *
लावळ / तहसील / तालुका * Purna

Town/City/Village *
शहर / गाव * asdf

Locality/Area Name/Post Office *
वास्तवार्थे ठिकाण / पोस्ट ऑफीस * asdf

Block No./Block Name/Street No./Street Name/ Sector No
ब्लॉक क्रमांक / ब्लॉक नाव / सेक्टर क्रमांक / रस्ता क्रमांक / रस्त्याचे नाव asdf

House No./Door No./Flat No./ Building No./Building Name/Lift No *
घर क्रमांक / झोपडपट्टी क्रमांक / इमारतीचे नाव * asdf

Pin code *
पिन कोड * 123123

Number of family members
सदस्य कुटुंबीय

Total Family Monthly Income *
कुटुंबाचे सद्य मासिक उत्पन्न *

Total Family Annual Income *
कुटुंबाचे सद्य वार्षिक उत्पन्न *

Purpose for applying for this certificate *
अर्ज करण्याचे कारण *

Submit

Exhibit 13 – Screen shot of the Single form for Income certificate for Maharashtra

Metadata standards

During the e-Forms Project, it was observed that the metadata standards provided by DIT were not sufficient to cater with all data fields in the forms. Therefore, a detailed discussion was carried out with subject matter experts and the metadata assumptions for such data fields. For example, in the service for “Inclusion of Name in the Electoral Rolls”, following table of assumptions was prepared by the team:

13.6.4 Officer view of the application form

Government officials dealing with e-Forms should be able to view exactly the same form as the paper forms. This is needed especially in departments where the back offices operations have not been computerized. The officer can work with the paper view that he is used to working with effortlessly, without need for any training on the new format of the e-Form. The exhibit shown below shows the officer view of the income certificate for the Maharashtra income certificate form discussed earlier. This is done by capturing all required fields in e-Form and then displaying them in the paper form view with the relevant details from the database.

SETU, DISTRICT OFFICE, THANE
Application form For
Income Certificate

To,
District Officer Thane
Applicant(Mr/Mrs) Manish Gupta
Village Thane Taluka Vasai District Thane

Subject: Annual Income Certificate

Sir,

I am living along with my family(10 members) at above mentioned address whose information is as per below

| Name | Age | Relationship | Occupation | Monthly Income |
|--------|-----|--------------|------------|----------------|
| Manish | 24 | Self | Service | 20000 |

Monthly Income 20000
Annual Income 240000

Exhibit 14 – Govt officer view of e-Form

13.6.5 Fulcrum – e-Forms Designer Tool from C-DAC

An e-Forms designer tool “Fulcrum” developed by C-DAC and owned by DIT is being hosted on the India portal at the URL eforms.gov.in. This would allow the states to create and maintain a repository of their e-Forms. This repository would have access control rights to ensure that only authorized people are allowed to view, create and update e-Forms. 40 template e-Forms would be available in the repository of each state to start with and they could then be accepted as it is or with modifications in the states repository. E-Learning and user manual would be made available on the portal to guide the states in the creation of e-Forms using the fulcrum tool. This is an optional feature and the states and Implementing Agencies are free to use a tool of their choice for e-Forms creation.

13.6.6 Destination office processing and MIS reports

In the PoC the centralized application provided for viewing of different reports based on role of the user. The destination office users are given user name and password and their role is defined in the centralized application database. The reports visible to him would be the ones listed under the dashboard for destination office. If an officer of a department uses the same centralized application he would get a different set of reports. These reports would give information pertaining to all the locations of the department as shown in the dashboard for the department subsection.

13.6.7 Destination Office Processing

Once the destination officer logs into the centralized application, he will be able to see all the applications which are submitted to that particular location. Below is a sample screen shot of the dashboard for the officer. There are four action icons given under the column task for him to perform.

The 4 actions that he can perform are:-

- a. **View the application:** - The officer can click on this button to view a particular application before he starts processing it.
- b. **Print the application:** - Officer can take out the print out of the application by clicking on the Print button
- c. **Update the status:** - The status of the application can be changed by the officer by clicking on the Update the Status Button.
- d. **Upload the certificate:** - Once the application has been processed and the certificate is ready to be issued, the officer has the facility to upload the scan copy of the certificate on the portal. He can do the same by clicking on the Upload the Certificates Button.

Implementation guidelines

| Sr No. | Service Name | File No | Applicant Name | Status | Tasks |
|--------|------------------------------|-------------|------------------|------------------------------------------|-------|
| 1 | MaharashtraIncomeCertificate | 11111153074 | aaaaaaaa | ApplicationUnderVerificationByDepartment | |
| 2 | MaharashtraIncomeCertificate | 11111153050 | Manish Gupta | CertificateReady | |
| 3 | MaharashtraIncomeCertificate | 11111153080 | Peeyush Chomal | INPROCESS | |
| 4 | MaharashtraIncomeCertificate | 11111153051 | Rohan V Kulkarni | ApplicationSubmittedSuccessfully | |
| 5 | MaharashtraIncomeCertificate | 11111153083 | Rohan V Kulkarni | Application Under Process | |
| 6 | MaharashtraIncomeCertificate | 11111153090 | aaaaaaa | INPROCESS | |
| 7 | MaharashtraIncomeCertificate | 11111153092 | Anil Mehta | INPROCESS | |
| 8 | MaharashtraIncomeCertificate | 11111153093 | Rohan V Kulkarni | INPROCESS | |
| 9 | MaharashtraIncomeCertificate | 11111153098 | Neeru Kapil | Certificate Ready | |
| 10 | MaharashtraIncomeCertificate | 11111153099 | sadsadsad | Certificate Ready | |

Exhibit 15 – Destination Office user screenshot

13.6.8 Dashboard for Department

A department officer is able to view the status of all the applications for all the field locations of the department. The screenshot below shows the application requests status and count for each location in a tabular format.

Implementation guidelines

| Office Registration | | | | | | |
|---------------------|------------------------------|---------------|-------------|------------|------------------------------------|-------|
| Sr.NO | Service Name | District | SubDistrict | Date | Status | Count |
| 1 | MaharashtraIncomeCertificate | Akola | Balapur | 2009-09-25 | RECIEVED | 3 |
| 2 | MaharashtraIncomeCertificate | New Delhi | null | 2009-08-07 | INPROCESS | 1 |
| 3 | MaharashtraIncomeCertificate | Thane | Vasai | 2009-07-27 | Certificate Ready | 1 |
| 4 | MaharashtraIncomeCertificate | Akola | Balapur | 2009-09-25 | INPROCESS | 1 |
| 5 | MaharashtraIncomeCertificate | Mumbai-City | Mumbai-City | 2009-08-05 | Application Under Process | 1 |
| 6 | MaharashtraIncomeCertificate | Mumbai-City | Mumbai-City | 2009-07-27 | Application Submitted Successfully | 1 |
| 7 | MaharashtraIncomeCertificate | Central Delhi | null | 2009-09-08 | INPROCESS | 1 |
| 8 | MaharashtraIncomeCertificate | Mumbai-City | Mumbai-City | 2009-09-10 | INPROCESS | 1 |
| 9 | MaharashtraIncomeCertificate | Nagpur | Katol | 2009-09-25 | RECIEVED | 2 |
| 10 | MaharashtraIncomeCertificate | Mumbai-City | Mumbai-City | 2009-08-13 | INPROCESS | 1 |

Go to Page : [First](#) [Next](#) [Last](#)

Exhibit 16: Dashboard for the Department

13.6.9 Flow Diagram - e-Forms PoC

13.6.9.1 Flow Diagram for Registration Form

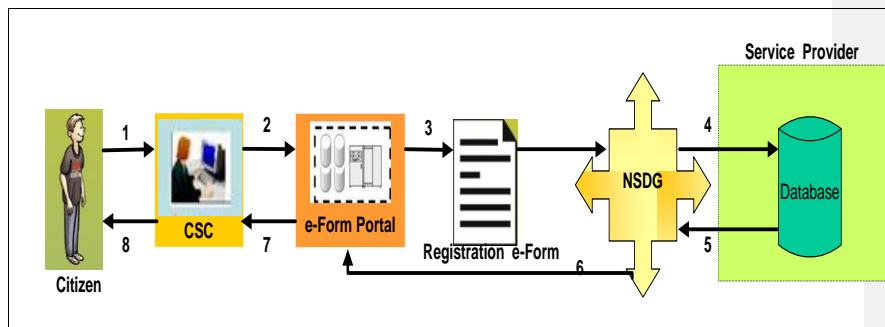

Exhibit 17 – Flow Diagram of filling the Registration Form

Implementation guidelines

To avail any of the services, citizen is required to register on the portal. The steps below define the registration process.

- Step 1:- He approaches CSC office to avail the service.
- Step 2:- The citizen would fill in the registration form.
- Step 3:- The data submitted by the user will be routed via NSDG.
- Step 4:- The data will be saved into the database.
- Step 5:- The generated unique Registration ID number will be sent to NSDG.
- Step 6:- NSDG will route this number to portal.
- Step 7:- CSC officer will view this number on the portal of the requested citizen;
- Step 8: The officer gives the registration number to the citizen. Citizen is required to keep this number safely and should use this ID to avail the various citizen services in future.

13.6.9.2 Flow Diagram for Service Form

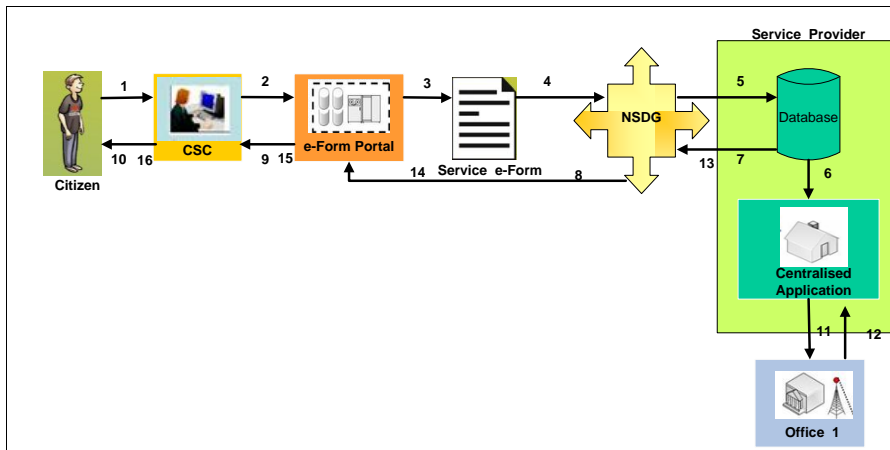

Exhibit 18 – Flow Diagram of a service request

Step 1:- Citizen comes to CSC office to avail any of the services and gets his Registration ID (obtained earlier or registers afresh if this is his first visit as described earlier).

Implementation guidelines

Step 2:- CSC officer logs to portal and gets the e-Form for the service which the user desires.

Step 3:- CSC officer feeds the Registration ID and fills the data for the requested service.

Step 4:- The data submitted by the user will be routed over NSDG.

Step 5:- The data will be saved into the database and the application would be intelligently routed to the department server for that service.

Step 6:- The department application would generate a unique request ID number (application number) for the application.

Step 7:- Centralized application sends this number to NSDG.

Step 8:- NSDG routes this number to the e-Form application/portal.

Step 9:- CSC officer will view this number on the portal of the requested citizen; the officer should print this acknowledgment for the citizen.

Step 10:- Citizen is required to use this Service ID for further reference and to check the updated status of the service request on the portal.

Step 11:- The concerned officer of the department logs into the centralized application and gets the request.

Step 12:- He processes the request and updates the response in the database.

Step 13:- The centralized application sends the response to NSDG.

Step 14:- NSDG routes this response back to the e-Form application/portal.

Step 15:- CSC user gets the response on the portal.

Step 16:- The citizen gets the response to his request from the portal.

13.6.10 Learnings from e-Forms PoC

In the course of preparation and execution of the e-Forms PoC exercise, many challenges were faced by the team. The following points list the key challenges faced during the project along with the proposed solutions. These learnings would be very useful in the subsequent phases of implementation of e-Forms.

Implementation guidelines

Challenge: - The physical forms or the paper based forms provided by the states were in their local languages.

Solution: - The final e-Forms should be multilingual for the convenience of the citizens. The states to provide the forms in English.

Challenge: - The applicant and the end user of the services may be two different people. There are no set guidelines on who is authorized to submit forms on someone else's behalf.

Solution: - States to issue guidelines indicating who can fill the form for whom.

Challenge: - Each e-Form had different content structure; therefore, there was a need to validate the submitted data at back end service before storing in database.

Solution: - A generic data model was conceived. XML Schema Definition (XSD) specific to each service (conforming to the generic data model) was built which would be used for the purpose of validation to ensure correctness of data submission by the citizen.

Challenge: - Application specific connectors were customized specific to each e-Form. These application connectors sit between Service Access Provider(SAP) generic connector and the e-Form. Their responsibility is to perform Front end server side validations against each service requirements before submission to Gateway.

Solution: R & D effort was undertaken by C-DAC. Application connectors were built conforming to the generic data model. These Application Connectors were deployed in Portal for the purpose of carrying out front end validation of Citizen Data submission against the XSDs defined.

13.7 Annexure VII - Guidelines for States and Implementation Agencies

These guidelines are consolidated from the guidelines that DIT has been publishing to the state from time to time and from the recommendations of the round table summit conducted by IBSG, CISCO.

- State/UT notifies its designated Nodal Agency, which shall be responsible for the execution of the project.
- The State may need to prioritize the departments and services and take into account the following:
 - i. High Volume Services – Services having high volumes of transaction so that there is maximum impact.
 - ii. MMP Services – Services already identified under State MMPs where work is yet to start and which are not covered under High Volumes Services.
 - iii. Any other services which the State wants to include because of their high Citizen Relevance.
- After the submission of Proposal and before the finalization of RFP, the States/UTs may like to formalize arrangement with the departments concerned, regarding processing of electronic requests received. This arrangement should lay down the respective duties and obligations of each entity in respect of each service proposed to be made available electronically as well as the service charges for the same and the apportionment thereof between the CSC/SCA and the other entities involved as may be decided by the state. This is a condition precedent to actual implementation. It is suggested that the above said commitment of participating departments may be solicited through aegis of the Apex Committee headed by the Chief Secretary.
- The State/UT forms a State Implementation Committee for this project. Representatives of CDAC & NIC should be members of this Committee.

Implementation guidelines

- The Application, SSDG and Portal shall be certified by STQC against the quality framework and Standards and the guidelines issued by DIT, GoI.
- State to Issue notification after the implementation that departmental Forms will not be valid unless hosted on the State Portal. Further, downloading and processing of e-Forms published on the State portals is mandatory by the recipient department.
- States to issue necessary notification with regard to electronic service delivery. Draft of the electronic service delivery document is placed in Annexure. States may use this as a guideline and issue relevant notifications.
- States where edistrict pilot is already under progress or the services are offered electronically through some other portal, the implementation agency must analyze the existing forms while finalizing the forms for these services.
- States should define the process by which changes to the e-Forms would be communicated to the CSC's so that they do not continue to use older downloaded versions.
- One state, one service: One form. In a State/UT there should be only one form for each service. There should not be any variation from district to district.
- Forms may be divided into Part-I and Part-II
 - Part-I: Common fields across forms like name, father's name, d.o.b., address etc.
 - Part-II : Fields relating to that service
- The back-end formats and database fields should be standardized.
- Technology should be so chosen so that integration & inter-operability with other applications/ MMPs are possible at a later date. This will lead to convergence
- Technology should allow to bring in possible variants in future
- e-Form should be intelligent to do some preliminary checks to ensure all relevant columns are filled

Implementation guidelines

- The acknowledgement number assigned to each application has to be unique at the national level for ease of tracking, generation of statistics, monitoring of disposal of applications etc. Acknowledgement Number is to be generated by the software at State Portal. To enable people to track the status of their applications on mobile phones, the acknowledgement number should be numeric.
- In case Internet connectivity is not available at the time of submission, the same will be provided later and hence e-Form engine should work in off-line mode as well so that data can be captured when people visit the CSC and submission can take place whenever connectivity gets established
- While making application through CSC there could be three types of fees namely CSC transaction fees, Application fee or processing fees fixed by the Department and the cost of courier charges if the service is to be delivered at the residence of the applicant or at CSC. Current law does not permit CSCs to collect and keep the transaction charges. The application should enable collection of fees once suitable amendments are made to the laws.
- Tracking of application status via multiple modes like IVR, SMS.
- Delivery of service to applicant can be done in different ways, depending on the sensitivity of service. The group recommended the following:
 - Online (through CSC and State Portals) – For non-critical/ less-sensitive services
 - Through post/courier, at the address, on production of proof of identity.
 - Pick up from relevant government office after presenting original supporting document.
- Wherever possible review the need for supporting documentation and eliminate need for scanning/submission
- At the time of applicant registering at State Portal (Part-I of form), s/he may be asked to show original supporting document at some designated office or before VLE, if VLE is declared notary by State Government. This will be one-time activity.

Implementation guidelines

- The other option could be to upload scanned copies once for subsequent reference. Such scanned documents could be tagged with the unique Id provided to applicant. The reference number of supporting document like certificate/license/EPIC etc. could be entered in the database along with date of issue and issuing authority (from drop down menu). The details of all offices have to be entered by State governments and hence they will be available in the database. This will help creation of database of certificates/licenses etc already issued to people in past and ease of cross-referencing.
- The e-Form should clearly indicate supporting documents required and it should have check boxes against each supporting document. Marking the check box should be mandatory while filling up the form.

13.8 Annexure VIII - Security Services by SSDG for SP/ Govt. Dept.

Security forms an important aspect of SSDG. The transaction scenarios have a strong requirement for security. The SSDG provides following security features:

1. **Secure Communication Channel:** The communication with SSDG has been designed to be over client authentication TLS/SSL. This guarantees the authenticity and the integrity of the business data and service envelope over the communication channel. To prevent “man-in-middle” attack” the TLS/SSL has been configured to use Message Authentication Code (MAC/HMAC) while messages are exchanged. The TLS/SSL provide for following verification:
 - a. The client & server is configured to use the certificate issuing CA’s *public key* to validate the trust of the SSL signature;
 - b. The client & server checks the certificate validity period;
 - c. The client & server checks the revocation status of the certificate;
 - d. For more secure channel between SSDG & SP the client can be configured to validate the server certificate with server certificate public key.
 - e. Failure in any of the above will terminate the SSL/TLS session.

2. Sender (SAP) Authentication & Authorization: Each service request from the SAP is forwarded to SP after performing authentication and authorization of the SAP for the particular service.

- a. Authenticity of the Sender (SAP) of each service request is established at the SSDG either by W3C XML Dsig or by login-password as specified at the time of registration of the sender. The GSD provides facility to the SP/Govt. Department to specify the method of authentication (DSIG/Password) while integrating the service with the SSDG.
- b. All registered SAP with SSDG is not entitled to access all services integrated with the SSDG. Authorization to access a service is based on the bi-lateral agreement between SP/Govt. Department and SAP. The SSDG performs the authorization on basis of this information provided by the SP/Govt. Department.

Comment [k2]: Is it Digital Signature

3. Integrity: The SSDG provides an optional feature whereby end to end business payload integrity can be established. This is accomplished by usage of W3C XML Dsig. If a service warrants the integrity following additional activities to be carried

- a. Sender digitally signs the business payload and sends the request along with the signature.
- b. The SP on receiving establishes the integrity of the payload by validating the signature

The above mentioned security service is provided as part of SAP and SP generic connector.

4. Non-repudiation of message receipt: The SSDG ensures non-repudiation of message receipt by SP/SAP by maintaining the Acknowledgements on successful delivery of the message.

5. Confidentiality: Confidentiality during communication is ensured by usage of Client authentication SSL/TLS. Confidentiality at server is ensured through Access control mechanism.

II. Extended Security Services which can be built on top of existing Security services

1. **Access Control at SP:** The Client Authentication SSL/TLS can be configured to identify and control access. The SP SSL configuration can be set up to enable access to only a

Implementation guidelines

specific Server (SSDG) by including the public key of the SSDG SSL certificate into the trusted keystore.

2. **Non-repudiation of sending Message:** Non-repudiation refers to both the authorship of the message and to the communication process. The communication process is explained above. The Non-repudiation of authorship can be accomplished by signing business data and sending the business data along with the signature as part of the business payload. If more than one author exists, then each needs to sign and the signature be send along with the business data. The process ensures that the sender cannot successfully deny having sent a certain message.
3. **Confidentiality:** For services requiring very high level of confidentiality the business data before submission to SSDG can be encrypted and send as business payload. The same can be decrypted at receipt site after extracting the business payload.

The SSDG ensures that no communication between the SP/Govt. Dept and Service Access Point (SAP)/front-end can happen without bilateral agreement.

The security compliance shall be as per ISO 27001:2005.

13.9 Annexure IX- Electronic Service Delivery (ESD) Rules

1. Short title, extent and commencement:-

- a. These rules may be called the Information Technology (Electronic Service Delivery) Rules, 2009.
- b. They shall extend to the whole of India.
- c. State Governments can adopt these rules or notify their own rules under section 90 of the Information Technology Act, 2000 (Central Act 21 of 2000).
- d. They shall come into force on the date of their publication in the Official Gazette.

2. Definitions- In these rules, unless the context otherwise requires, -

- a. “**Act**” means the Information Technology Act, 2000 (Central Act 21 of 2000);

- b. **“Signing Authority (SA)”** means a statutory authority or Government authority empowered under any Act, Rules, Regulations or Order of the Government to issue a certificate;
- c. **“Electronic Service Delivery” (ESD)** means the delivery of public services in the form of receipt of forms and applications, issue or grant of any license, permit, certificate, sanction or approval and the receipt or payment of money by electronic means by following the procedure specified hereunder;
- d. **“Certificate”** means a certificate required to be issued by a statutory authority empowered under any Act, rule, regulation or Order of the Government to issue a certificate to confirm the status, right or responsibility of a person, natural or artificial, in accordance with any such Act, rule, regulation or Order of the Government and includes a certificate in electronic form printed and issued by an authorized agent on such special stationery as may be specified by the appropriate authority;
- e. **“Service Provider”** means any individual, private agency, private company, partnership firm, sole proprietary firm or any such other body or agency including Government Departments, Agencies, Public Sector Enterprises and Corporations which have been granted permission by the appropriate Government to offer services through Electronic means in accordance with the policy governing such sector;
- f. **“Authorized Agent” (AA)** means an operator of an electronically enabled kiosk or Front office who is permitted under these rules to deliver public services to the users with the help of a computer resource, by following the procedure specified herein;
- g. **“Repository of Digitally Signed Electronic Records”** means a collection of data or information created, stored and managed centrally by the appropriate Government in electronic form, and authenticated by a statutory authority or Government Authority using his or her Digital Signature Certificate;
- h. **“Official Gazette”** means the Official Gazette of the Government;

3. System of Electronic Service Delivery:-

- a. It shall be lawful for the Government and Statutory Authorities to deliver public services through electronically enabled kiosks or through other online delivery systems, adopting the system of Electronic Service Delivery or ESD, in accordance with these rules.

Implementation guidelines

- b. The nature of the license, permit, certificate, sanction or approval and of the receipt or payment of money, which may be effected under the system of Electronic Service Delivery, shall be such as those notified by the appropriate Government in this regard (hereinafter referred to as the “notified services”).
- c. The appropriate authority shall notify the Service Providers and their authorized agents who are authorized for Electronic Service Delivery, for services specified, in accordance with these rules.
- d. Any license, permit, certificate, sanction or approval delivered in accordance with these rules shall be admissible in any proceedings, without further proof or production of the original, as evidence of any contents of the original or of any fact stated therein of which direct evidence would be admissible, provided it is verifiable by one or more of the three procedures as explained below:
 - i. The license, permit, certificate, sanction or approval has a unique identification number which can be used to verify its authenticity and content from the website of the agency issuing it.
 - ii. The license, permit, certificate, sanction or approval has a bar code which can be used to verify its authenticity and content.
 - iii. The license, permit, certificate, sanction or approval can be verified with the digital signatures of the authority which has issued it.
- e. The receipt or payment of money by or in favor of the appropriate Government adopting the system of Electronic Service Delivery shall be deemed to be a receipt or payment effected in compliance with the financial code and treasury code of such Government.
- f. It shall be lawful for the Service Providers and their Authorized Agents to collect retain and appropriate such service charges as may be prescribed by the appropriate Government for the purpose of providing such services from the person availing such services.
- g. Subject to the provisions of subsection (5) above, the appropriate Government may authorize the Service Providers and their Authorized Agents to collect, retain and appropriate service charges under this section notwithstanding the fact that there is no express provision under the Act, rule, regulation or notification under which the service is provided to collect retain and appropriate e service charges.
- h. The appropriate Government shall by notification in the Official Gazette specify the scale of service charges which may be charged and collected by the Service Providers and their Authorized Agents for various kinds of services.

4. Notification of Electronic Service Delivery:-

- a. The appropriate authority may notify the services that will be delivered electronically in accordance with these rules.
- b. The appropriate authority may notify any computer, computer system or computer network located within the jurisdiction the appropriate authority as 'protected systems', within the meaning assigned to the same under the Act, and such other powers as the Government may notify from time to time.
- c. The appropriate authority shall identify and notify the list of Signing Authorities in respect of different classes of certificates and local limits of their respective jurisdictions. The notification shall specify the nature of certificate, the names of the Signing Authorities approved by the appropriate Government, the period of effectiveness of the authority and the extent of their jurisdiction.
- d. The appropriate authority shall notify changes to the list of Signing Authorities (SA) from time to time, taking into consideration the retirements, transfers, suspensions or termination from services of employees holding positions of SA. To this extent, it shall be the responsibility of the respective appointing authorities of SAs to inform the appropriate authority within seven days of such changes.

5. Creation of repository of digitally signed electronic records by Government Authorities.

- a. All Government Authorities that issue any license, permit, certificate, sanction or approval, electronically may, as soon as can be, after the coming into effect of these rules, will create, establish and maintain a repository of digitally signed electronic records of such licenses, permits, certificates, sanctions or approvals, as the case may be.
- b. Such authorities may digitally sign the electronic records of such licenses, permits, certificates, sanctions or approvals by each record or as a whole.
- c. For the purposes of compliance with the provisions of sub-rule (1), it shall be adequate if the Head of the Department controlling several Statutory Authorities or Government Authorities empowered to issue licenses, permits, certificates, sanctions or approvals, creates, establishes and maintains a centralized application and a repository of digitally signed electronic records for

management of such licenses, permits, certificates, sanctions or approvals, as the case may be, and provides secure access to such Statutory Authorities or Government Authorities to enable them to create, update and digitally sign the electronic records relating to such licenses, permits, certificates, sanctions or approvals.

- d. The specified security procedures shall be followed by the Head of the Department and the Signing Authorities, in respect of the electronic data, information, applications, repository of digitally signed electronic records and IT assets under their respective control.

6. Procedure for making changes in a repository of digitally signed electronic records:-

- a. Any Government Authority either suo motto or on an application made by an interested party, may, make or order to make an appropriate change in a repository of digitally signed electronic records, after following the procedure prescribed in the relevant Act, rule, regulation or Order.
- b. Any such authority shall have privilege for making or ordering changes only in respect of the electronic records pertaining to its own jurisdiction.
- c. Any change effected to any record in a repository of digitally signed electronic records and any addition or deletion of a record from such repository of digitally signed electronic records shall invariably be digitally signed by the respective authority.
- d. It shall be the responsibility of the authorities specified in sub-rule 1 of rule 15 and of the Head of Department specified in sub-rule 3 of rule 15, to ensure that the repositories of digitally signed electronic records in their custody have been preserved in the normal course, in accordance with the prescribed security procedures.

7. Responsibility of Service Provider and authorized agents for financial management and accounting:-

- a. Every Service Provider and authorized agent shall keep an updated and accurate account of the transactions, receipts and vouchers in respect of the electronic services delivered, in the specified format.

Implementation guidelines

- b. The appropriate authority shall specify the formats for maintaining of the account of transactions, receipts and/or payments, in electronic form by authorized agents.

8. Audit of the Information Systems and Accounts of Service Provider and authorized agents:-

- a. The appropriate authority may cause an audit to be conducted of the affairs of the Service Providers and authorized agents in the State at such intervals as deemed necessary by nominating such audit agencies.
- b. Such an audit may cover aspects such as the security, confidentiality and the privacy of information, the functionality and performance of any software application used in the ESD and the accuracy of accounts kept by the Service Providers and authorized agents.
- c. It shall be incumbent on the Service Providers and the authorized agents to provide such information and assistance to the audit agencies nominated by the appropriate authority to comply with the directions given by the audit agencies and to rectify the defects and deficiencies pointed out by the audit agencies.

9. Use of special stationery in ESD:-

- a. The appropriate authority may specify that the printouts of the specified type of documents shall be made only on such special stationery as may be specified.
- b. The appropriate authority may specify different types of special stationery with accompanying security features for different services and types of documents.

10. Removal of Difficulties.

- a. If any difficulty arises in giving effect to the provisions of these Rules, the appropriate Government may, by order published in the Official Gazette, make such provisions not inconsistent with the provisions of these Rules as appear to it to be necessary or expedient for removing the difficulty.
- b. Every order made under this rule shall be laid, as soon as may be after it is made, before the Parliament or State's Legislative Assembly as the case may be.

11. Miscellaneous

- a. The appropriate authority, by notification in the Official Gazette, may specify, -
 - i. The manner of creating, establishing and maintaining the repository of digitally signed electronic records specified in sub-rule (1) of rule 5;
 - ii. the manner of encrypting sensitive electronic records requiring confidentiality, while they are digitally signed;
 - iii. The manner of implementing the security procedures referred to in sub-rule (4) of rule 5, including the requirements for the storage and management of cryptographic keys, restrictions for downloading the certificates onto browsers, and of complying with the requirements of registration authorities.
 - iv. the requirements for maintaining audit trails of all changes made to repository of digitally signed electronic records, specified in rule 6;
 - v. the manner of digitally signing the event of deletion of a record from the repository of digitally signed electronic records, referred to in sub-rule (3) of rule 6;
 - vi. the manner of provisioning secure access to the repository of digitally signed electronic records;
 - vii. the norms on the service levels to be complied with by the Service Provider and the authorized agents;
 - viii. procedure for online verification of transactions, envisaged in subsection (3) of rule 3;
 - ix. Formats for maintenance of accounts, as specified in rule 7.

13.10 Annexure X - Status report template

The consultants shall report the status of the project every month in the following format

<< *State* >>

State Contact:

Consultant:

Dt :

| Business Milestone | Planned Closure Date |
|--------------------------------------------------------------------------------------|-----------------------------|
| Apex Committee meeting | |
| SPC Constitution | |
| Selection of Consultant | |
| Agreement with Consultant | |
| Advance payment to Consultant | |
| Finalize Services and the process flow for the list of services to be e-Form-enabled | |
| Finalize the content to be published | |
| Formalization of Arrangement with State | |
| Change management strategy and communication | |
| Functional Requirement Specifications (FRS) | |
| RFP preparation | |
| | |
| | |

| Accomplishments so far (Last Fortnight) |
|------------------------------------------------|
| << Last fortnight accomplishment >> |
| |
| |

| Upcoming Activities (In the next 15 days) |
|--------------------------------------------------|
| |
| |
| |

| Risk/Issues | Mitigation | Due date |
|--------------------|-------------------|-----------------|
| | | |
| | | |
| | | |

| Major Dependencies |
|---------------------------|
| |
| |
| |

